



GM9907-L2

User's manual

**GM9907-L20190200
110608040007
V03.01.06_1**

© 2020 Shenzhen General Measure Technology Co., Ltd. All rights reserved.

No unit or individual may copy, distribute, transcribe or translate into other language versions in any form or by any means without the permission of Shenzhen General Measure Technology Co., Ltd.

As our products have been continuously improved and updated, our company reserves the right to modify this manual at any time without prior notice. To do this, please visit the company website frequently to get timely information.

Company website <http://www.szgmt.com> www.gmweighing.com

Implementation standards of this product: **GB/T 7724—2008**



Content

| | | |
|---------|--|--------|
| 1. | Outline | - 1 - |
| 1.1 | Functions and Features | - 1 - |
| 1.2 | Front panel description | - 1 - |
| 1.3 | Rear panel description | - 3 - |
| 1.4 | Technical Specifications | - 3 - |
| 1.4.1 | General Specifications | - 3 - |
| 1.4.2 | Analog part | - 3 - |
| 1.4.3 | digital part | - 4 - |
| 2. | Installation | - 5 - |
| 2.1 | General principles | - 5 - |
| 2.2 | Load Cell connection | - 5 - |
| 2.3 | I/O Module Port connection | - 5 - |
| 2.4 | Power supply connection | - 6 - |
| 2.5 | Serial port connection | - 6 - |
| 2.6 | Touch screen calibration | - 7 - |
| 3. | User Manage | - 8 - |
| 4. | Menu | - 9 - |
| 4.1 | Calibration | - 10 - |
| 4.2 | Recipe paracontrollers | - 11 - |
| 4.2.1 | Scale body structure paracontrollers | - 14 - |
| 4.3 | Weight paracontroller | - 17 - |
| 4.4 | System Maintenance | - 18 - |
| 4.4.1 | Weigher structure | - 18 - |
| 4.4.2 | Communication Setting | - 22 - |
| 4.4.3 | User Logic | - 23 - |
| 4.4.3.1 | Delay on | - 24 - |
| 4.4.3.2 | Delay off | - 25 - |
| 4.4.3.3 | Delay on and delay off | - 26 - |
| 4.4.3.4 | Invalid - valid edge triggered | - 26 - |
| 4.4.3.5 | Valid - invalid edge trigger | - 26 - |
| 4.4.4 | Peripheral paracontrollers | - 27 - |
| 4.4.5 | Factory reset | - 28 - |
| 4.4.6 | Hardware setting | - 29 - |
| 4.4.7 | Style setting | - 29 - |
| 4.5 | Peripheral paracontrollers | - 29 - |
| 4.6 | Motor paracontroller | - 34 - |
| 4.7 | Statistics | - 40 - |
| 4.8 | I/O Module | - 41 - |
| 4.8.1 | Output, input port definition | - 43 - |
| 4.9 | Host mode | - 51 - |
| 5. | Function | - 53 - |
| 5.1 | Setting the working mode | - 53 - |
| 5.2 | Batches | - 53 - |
| 5.3 | Level control | - 53 - |
| 5.3.1 | Double digit | - 53 - |
| 5.3.2 | Single Level | - 53 - |
| 5.4 | Quick setup | - 54 - |
| 5.5 | Adaptive function | - 55 - |
| 5.6 | U disk upgrade software | - 55 - |

| | |
|--|---------|
| 5.6.1 Upgrade process | - 55 - |
| 5.6.2 U disk upgrade boot interface | - 55 - |
| 5.7 U disk upgrade boot interface | - 55 - |
| 5.8 Decoupling function | - 56 - |
| 5.9 Running mode of bracket | - 56 - |
| 5.10 Use method of 3 - class conveyor for ton baling scale | - 57 - |
| 6. Serial communication | - 59 - |
| 6.1 Printing method | - 59 - |
| 6.1.1 Auto print | - 59 - |
| 6.1.2 Total cumulative printing | - 60 - |
| 6.1.3 Formula cumulative printing | - 60 - |
| 6.1.4 User cumulative printing | - 60 - |
| 6.2 Continuons mode data frame format | - 61 - |
| 6.3 Re-Cont specific protocol | - 61 - |
| 6.4 Modbus-RTU Protocol | - 62 - |
| 6.4.1 Abnormal function code and code | - 62 - |
| 6.4.2 MODBUS transmission mode | - 62 - |
| 5.3.3 MODBUS address allocation | - 63 - |
| 7. Automatic bagging process | - 94 - |
| 7.1 With a single scale hopper | - 94 - |
| 7.2 Without a single scale hopper | - 96 - |
| 7.3 Tons of package scale | - 98 - |
| 7.4 Valve port scale | - 99 - |
| 7.5 PLC mode | - 100 - |
| 7.6 Double scale interlocking bagging mode | - 100 - |
| 8. Motor working process | - 102 - |
| 8.1 Motor filling section | - 102 - |
| 8.1.1 Stepper motor filling | - 102 - |
| 8.1.2 Ordinary motor filling | - 102 - |
| 8.2 Motor lock bag part | - 103 - |
| 8.2.1 Step motor lock unlock bag | - 103 - |
| 8.2.2 Motor double limit lock unlock bag | - 104 - |
| 8.2.3 Motor single limit lock unlock bag | - 104 - |
| 8.3 Motor discharge part | - 104 - |
| 8.3.1 Stepper motor discharge | - 104 - |
| 8.3.2 Motor single limit discharge | - 105 - |
| 8.3.3 Motor double limit discharge | - 105 - |
| 8.3.4 Motor one-way rotary discharge | - 106 - |
| 8.3.5 Motor debug function | - 106 - |
| 9. Peripheral workflow | - 108 - |
| 9.1 Pat bag | - 108 - |
| 9.2 Coding | - 108 - |
| 9.3 Conveyor | - 109 - |
| 9.4 Printing | - 109 - |
| 9.5 Sewing machine | - 109 - |
| 9.6 Discharge Patting | - 110 - |
| 9.7 Filling/Discharge Overtime Paracontroller | - 110 - |
| 9.8 Auxiliary Pulse | - 110 - |
| 10. Dimension (mm) | - 112 - |

1. Outline

GM9907-L2 bagging controller is a new weighing control controller specially developed for the single scale incremental method automatic quantitative packing scale. The controller English displays interface for easy operation; completely new algorithm coarser and more accurate control so that the load; the USB port and dual port serial device to make it easier to system interconnect. It can be widely used in fill, chemical, grain and other industries that require quantitative packaging equipment.

1.1 Functions and Features

- Full English display interface, make the operation more intuitive and easy
- There are five modes of bagging application, Net Weigher, Gross Weigher, Jumbo Bag, servo motor, PLC.
- **28**-digital input and output control (**12 in / 16 out**), input and output port positions can be customized.
- I/O Module test function, convenient for debugging of packing scale
- Fully automatic double material speed, three material speed filling control, with jog filling function
- Twenty formulas can be stored to facilitate bagging of different range materials
- USB interface facilitates import and export of various paracontrollers
- Fill control function, convenient control connection between bagging scale and front filling equipment
- Fill speed adaptive function
- IO User Logic programming
- Auto free fall correction function
- Multiple digital filtering
- Batch setting function
- Bag patting function, suitable for bagging of powder materials
- Automatic zero tracking
- Time / date function
- Three-level user identity setting
- Dual serial port, external serial printer, computer or second display
- With single port communication function, it is convenient to communicate with the host computer

1.2 Front panel description

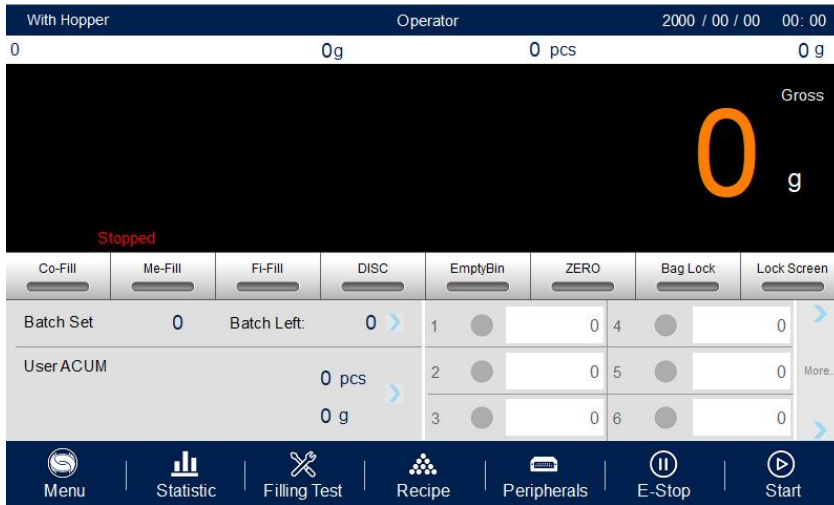

- ①User Info: Display the current login user ID, Recipe ID, System time, ACUM And Batch
- ②Weight status: Including weight value display, weight unit display, 8bit zone display and output I/O Module short cut key.
- ③Packaging information area: display current ACUM information, short cut setting batch and target value.
- ④Functional paracontroller area: Controller menu paracontrollers query Settings and the corresponding operation keys

Interface 1 description:

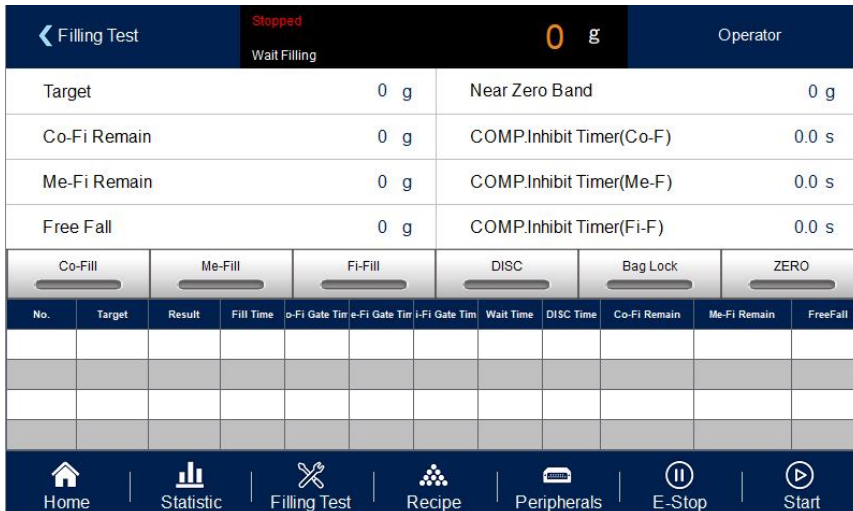

- ①Short cut set receipt pare: can quickly set receipt paracontroller.
- ②Packing history recording: can easily review current history data, easy to compare.

Indicator light description:

Left 1: power light;

Left 2: Serial port 1-RS232 communication indicator light, the indicator light flashes during communication

Left 3: Serial port 2-RS485 communication indicator light, the indicator light flashes during communication

1.3 Rear panel description

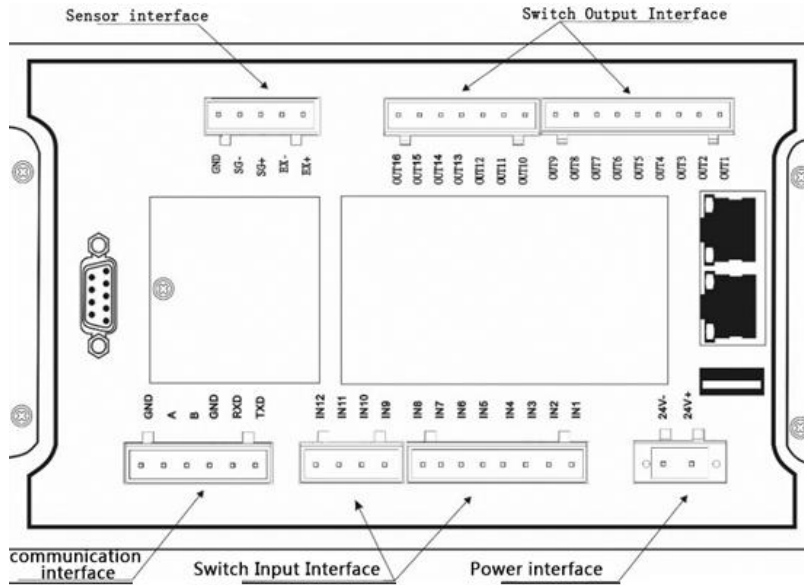

1.4 Technical Specifications

1.4.1 General Specifications

Power supply: DC24V

Power filter: included

Operating temperature: -10 ~ 40 °C

Maximum humidity: 90% RH non-condensing

Power consumption: about 15 W

Dimensions: 190 mm × 124 mm × 48 mm

1.4.2 Analog part

Load cell power supply: DC 5 V 125 mA (MAX)

Input impedance: 10MΩ

Zero adjustment range: 0. 00 2 ~ 15 mV (when load cell 3mV / V)

Input sensitivity: 0.02uV / d

Input range: 0. 0 2 ~ 15mV

Conversion: Sigma-Delta

A/D conversion speed: 120, 240, 480, 960 times / sec

Non-linear: 0.01% FS

Gain drift: 10PPM / °C

The maximum display accuracy: 1 / 100,000

1.4.3 digital part

Display: 7 inch resistive touch screen

Negative Number Display: "-"

Overload Indication: "Over Full Scale / Load cell Input Under."

Decimal point position: 5 optional

2. Installation

2.1 General principles

- 1) Make appropriate installation holes on the control box, (size: 179 (± 1) mm \times 113 (± 1) mm)
- 2) Install GM9907-L2 into a control box.
- 3) Remove the fixing plates on both sides of GM9907-L2, fix it with the fixing plates and lock them with M3*10 screws.

2.2 Load Cell connection

GM9907-L2 bagging controller can be connected to a resistive strain bridge load cell. When using a six-wire load cells, you must bridge the SN+ with EX+ and bridge the SN- with EX-

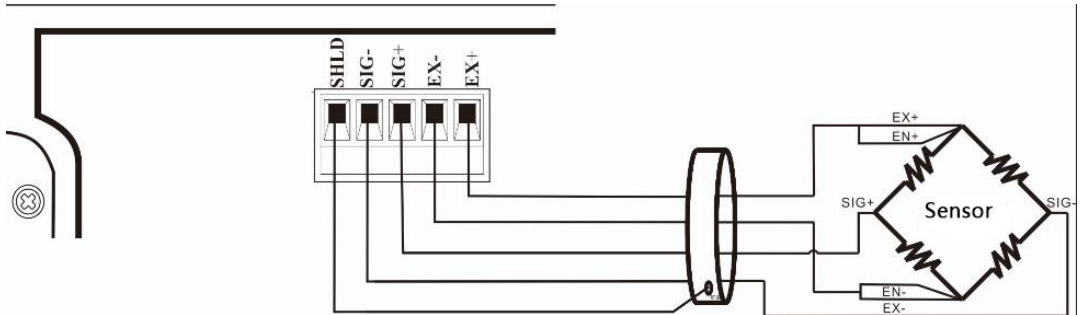

EX+ : Excitation+ EX- : Excitation- SN+ : Sense+ SN- : Sense- SIG+ : Signal+ SIG- : Signal-

2.3 I/O Module Port connection

GM9907-L2 bagging controller controls 28 lines I/O (12 input and 16 output). It uses optoelectronic isolation technology to transfer data. The I/O signal input is low level effective, and the output is open-collector mode. The driving current can reach 500mA and the full load current is up to 3A, and Terminal connection is shown as below:

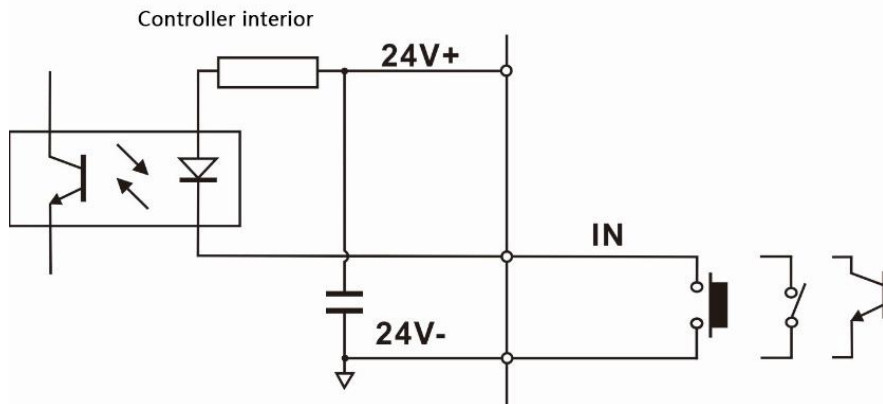

I/O Module Input port diagram

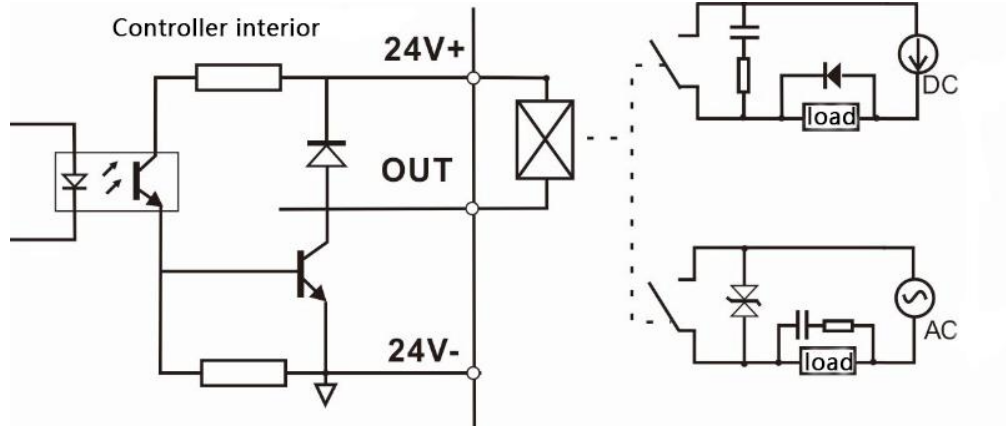

I/O Module output connection diagram

GM 9907-L2 I/O signals definitions refer Section **4.8**.

2.4 Power supply connection

GM9907-L2 bagging controller use 24V DC power supply. The connection is as shown below:

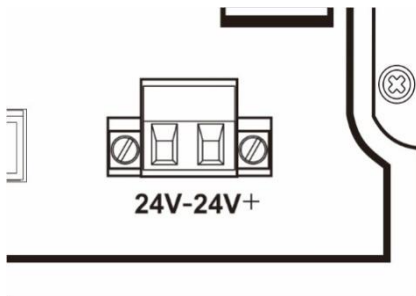

Power terminal diagram

24V+ connect DC+, 24V-connect DC-.

Note: this product use 24V DC power supply, use 220V AC power supply will permanently damage the controller and cause danger

2.5 Serial port connection

GM9907-L2 provides two serial ports as shown in the figure below. One is RS - 232 mode (terminal port TXD, RXD, GND); the other is RS - 485 , (terminal port A , B , GND). Serial port support: MODBUS protocol, continuous mode and print format.

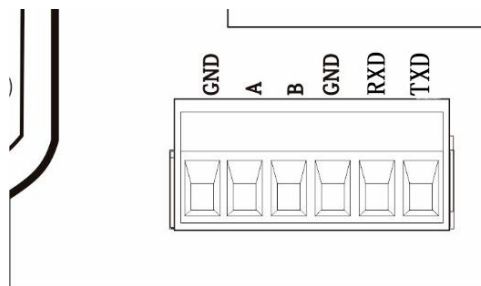

Controller and computer connection diagram

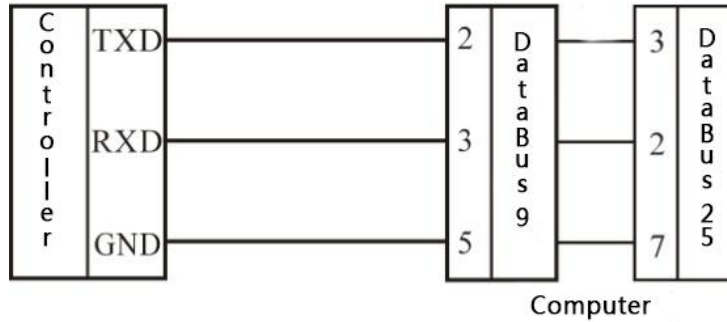

Controller and computer connection diagram (RS-232 mode)

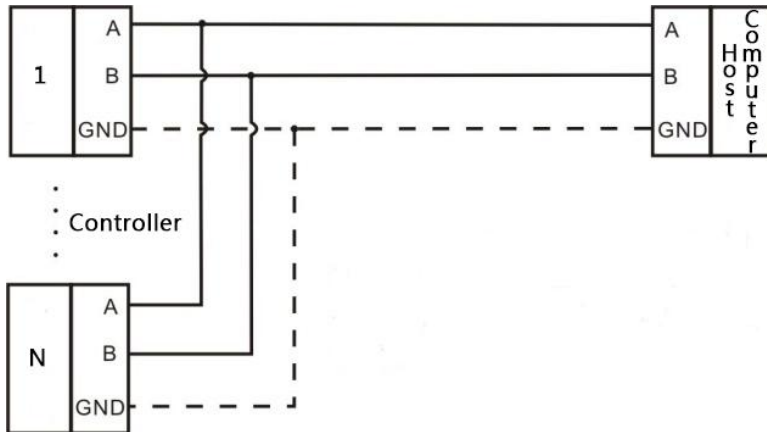

Controller and host computer connection diagram (RS-485 mode)

2.6 Touch screen calibration

Touch screen needs to be calibrated when the new product is used for the first time or after a long time. The touch screen calibration method:

GM9907-L2 power on, long press any point on the touch screen at the same time, system turn to touch screen calibration interface. Long press cursor position on touch screen, cursor position calibrate finish, after the interface displays the coordinates of this point, enter to next calibrate automatically. Follow cursor position changes long press accordingly, calibrate finish, and interface show 5 calibration point coordinates, enter to main interface automatically. If enter the calibration interface of the touch screen by mistake, press the "cancel" button in the lower right corner to exit the interface.

3. User Manage

In order to prevent the malfunction of the controller caused by the malfunction of the controller, the **GM9907** bagging controller provides **three** levels of authority (operator, Administrator and Engineer) to choose: where the **Engineer can perform all operations on the controller** (not open to the user) . Operator and Administrator permissions are as follows:

| User level | Permission |
|---------------|--|
| Operator | Can refer all paracontrollers |
| | You can set part of the quantitative paracontrollers and process paracontrollers of the formula paracontrollers, switch test, U disk data export. |
| | You can set batch on the main interface, clear the current formula accumulation, the current user accumulation, and operate the shortcut keys on the main interface. |
| Administrator | All operations are not restricted. |
| | Can calibrate the scale, set the weighing paracontrollers, set the formula paracontrollers in the scale structure paracontrollers and adaptive, over and under difference, drop correction and fine moving function paracontrollers, I/O Module definition, set the language and time, modify the host mode paracontrollers. |
| | Opened peripheral paracontrollers can be modified. |

Permission description:

- ◆ After the controller is power on, enter the permission selection interface, and enter the main interface after selecting the permission
- ◆ Operator have four login method: Single operator login, multiple operator login, single operator keyword login, multiple operator keyword login.
- ◆ In **【System Trial】 【Style setting】** parameter, set the multi-operator login function ON/OFF, turn ON, set the number of operator logins. This is used to set the login mode for multiple operators.
- ◆ In **【System Trial】 【Style setting】** parameter, set login operator need keyword ON/OFF, turn ON, this is used to set whether a password is required for operator login.
- ◆ Multi-operators are set to 8, operator~operator 8
- ◆ The operator cumulative data of single operator and multiple operators are merged into the user cumulative operator column in **【statistics】**
- ◆ Click the permission in the foreground, the logout pop-up window will pop up, you can logout the current permission to return to the permission selection interface. After the power is powered off and the system restarts, the rights are automatically deregistered.

4. Menu

Press menu, can refer and modify paracontrollers.

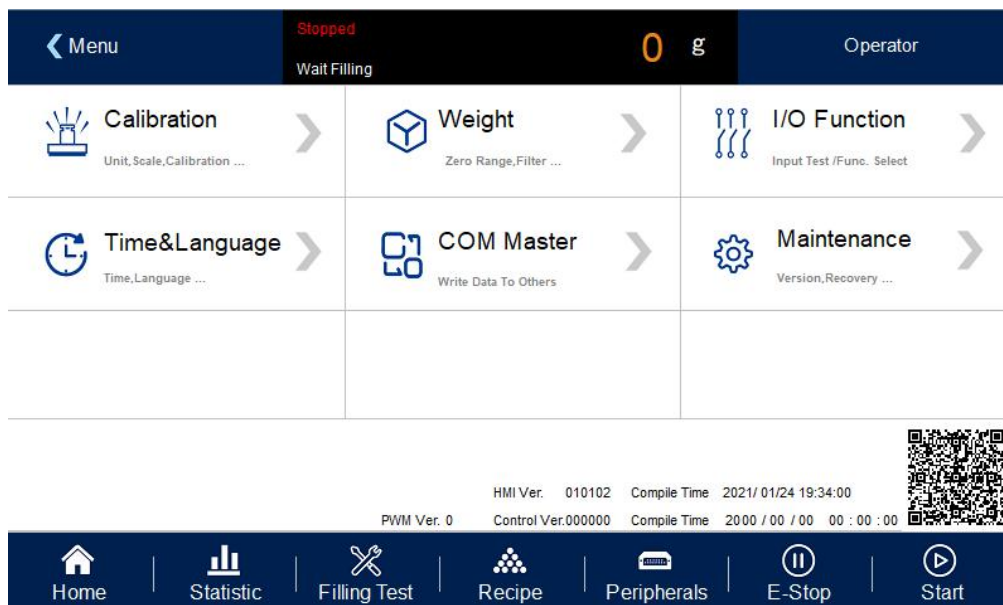

- ◆ Click paracontroller, enter current paracontroller to check, set paracontroller.
- ◆ Press [return] to exist current interface and return to the previous interface.

| Paracontroller item | paracontroller list | Paracontroller Description |
|-----------------------|---------------------------------|--|
| Calibration | weight calibration | Performs calibration operation for calibrating the controller weight value |
| | Material calibration | Perform calibration operation to calibrate controller weight value |
| Weight paracontroller | Zero range/filter lever setting | Set weight para, such as Zero range, stable para. |
| I/O Module | Input Define | Define the meaning of the controller input port |
| | Output Define | Define the meaning of the controller output port |
| Time and Language | Language Setting | Default Chinese, English optional. |
| | Time Setting | Set screen time. |
| Host computer mode | Computer communication | Set computer mode paracontroller. |
| Motor | Filling Paracontroller | Set filling related paracontrollers |
| | Bag Clutch paracontroller | Set the relevant paracontrollers of the bag clutch |

| | | |
|--------------------|--------------------------|---|
| | Discharge paracontroller | Set discharge related paracontrollers |
| System maintenance | Scale | Set scale structure, working mode, etc |
| | Communication setting | Set serial port, Ethernet, print etc. |
| | Logic edit | Auxiliary logic paracontroller: 6 group output logic paracontroller |
| | Peripheral ON/OFF | Set Peripherals paracontroller ON/OFF |
| | Factory default | Set paracontrollers factory default and backup. |
| | Hardware test | Test input and output connection. |
| | Style setting | Set screensaver timer |
| | Software upgrade | Software upgrade |

4.1 Calibration

The calibration scale is the calibration of the controller. When the GM9907 bagging controller or any part of the weighing system is changed for the first time and the current equipment calibration paracontrollers cannot meet the user's requirements, the controller should be calibrated. The calibration scale paracontroller directly affects the weighing result of the controller. To prevent personnel from mis operation, the Administrator and the Engineer are required to log in to calibrate the controller (select the identity login in the [User Login] option).

The calibration scale paracontroller of the national standard symmetrical heavy controller requires password protection. Therefore, the password must be entered correctly when entering the calibration paracontrollers (initial password: **000000**); the calibration password is changed in the "Password Management" item of [System Information].

In calibration interface, support two method: weight cal and material cal. Steps as follow:

| Calibration scale paracontroller | paracontroller | Description |
|----------------------------------|------------------|--|
| Weighing paracontroller | 1 unit | Initial value: kg ; g/kg/t/lb is available. |
| | 2. Decimal point | Initial value: 000; 0 to 0.0000 five kinds of options. |
| | 3. Resolution | Initial value: 1 ; 1/2/5/10/20/50 six optional . |
| | 4. Full Scale | Initial value: 100.00 ; The range is less than or equal to the minimum division $\times 10\ 0000$ can be set . |

| | |
|--|--|
| Weight Calibration | <p>The function of weight calibration is to use the weight calibration method in the field. Here are the steps:</p> <p>Step 1: Select weighing paracontrollers such as unit, decimal point and indexing value according to the demand.</p> <p>Step 2: Empty the bucket and click "Zero Calibration". This step is the zero point of calibration, the requirements are: the measuring bucket is empty, the scale body is stable.</p> <p>Step 3: Put weights on the weighing table. When the weighing table is stable, click [Weight Calibration], input the weight of weights in the bullet frame, and click OK to complete the calibration of weights.</p> |
| Material calibration(Only for With Net Weigher mode) | <p>Material calibration function in the field is not convenient to use the weight of the calibration method. Here are the steps:</p> <p>Step1: Empty the scale platform, wait for the millivolt to stabilize, and click "Zero calibration". This step is the zero point of calibration, the requirements are: the measuring bucket is empty, the scale body is stable.</p> <p>Step2: Click "Manual Filling", then the filling door will open, add material to the controlling bucket, click "Manual Filling" again to close the filling door. (If the manual filling time (Step2 time setting is manual filling time) is not set to 0, wait for the manual filling time to arrive, then automatically close the filling door)</p> <p>Step3: Click [Calibration of Unloading]. When the discharge door opens, the background will record the current relative millivolt. Weighing and recording the weight of discharged material.</p> <p>Step4: Click [Material Calibration], enter weighing data, and click OK. Material calibration is finished.</p> |

4.2 Recipe paracontrollers

Press recipe in Menu, enter 20 recipes choose interface, display recipe ID, name and target value.

- ◆ Click recipe ID, can swift recipe ID.
- ◆ Click recipe enter paracontrollers display
- ◆ Click upper left to return to the upper level interface.

| Recipe paraco ntroller item | paracontroller | Description |
|-----------------------------|--|--|
| Target | Used to set the bagging weight value related paracontrollers | |
| | 1. Target | Quantify the target value. |
| | 2. Coarse Flow Remains | In the quantification process, if the weighing value \geq the target value - Coarse Flow Remains, Coarse Fill is turned off. |
| | 3. Medium Flow Remains | In the quantification process, if the weighing value \geq the target value - Medium Flow Remains, Medium Fill is turned off. |
| | 4. Free Fall | In the quantification process, if the weighing value \geq the target value - Free Fall, Fine fill is turned off. |

| | | |
|----------------------------|---|---|
| | 5. Near Zero Band | In the quantification process, if the weighing value \leq Near Zero Band, Discharge Delay Timer is started. |
| | 6. COMP. Inhibit Timer(Co-F) | At the beginning of the value, in order to avoid overshooting without weight judgment during this time, Co-F has been effective. Initial value: 0.9; Range: 0.0~99.9.(unit: s) |
| | 7. COMP. Inhibit Timer(Me-F) | After the end of Co-F, in this period of time, in order to avoid overcharging without weight judgment, Me-F has been effective. Initial value: 0.9; Range: 0.0~99.9.(unit: s) |
| | 8. COMP. Inhibit Timer(Fi-F) | After Me-F, in this period of time, in order to avoid overcharging without weight judgment, Fi-F has been effective. Initial value: 0.9; Range: 0.0~99.9.(unit: s) |
| | Used to set the delay timer related paracontrollers of the filling process | |
| Time paracon troller | 1. Filling Start Delay | In Net Weigher mode, when the quantification process starts, after the delay time, the controller will stable and zeroing (if it does not meet the Zero Interval condition, it will not stable and not zeroing), and then start the filling process; In Gross Weigher mode, after lock bag is finished, after the delay time, the controller is to be stable and tare. Initial value: 0.5 ; Range: 0.0~99.9 . (Unit: s) |
| | 2. Result Waiting Timer | Result Checking Mode chose "Delay Timer", after the fine filling is turned off (or the Over/Under is turned on, the Over/Under alarm is finished), quantification process is started, and the holding time is passed, and the quantification process is finished, enter to next process. Initial value: 0.5 ; Range: 0.0~99.9 . (Unit: s) |
| | 3. Bag Locked Delay Timer | After the clutch bag signal is given, after the delay, controller judges that the bagging operation is completed. Initial value: 0.5 ; Range: 0.0~99.9 . (Unit: s) |
| | 4. Unlock Bag Pre-Delay Timer | After Net Weigher mode discharge is completed, the unlock bag signal is output after the delay time; After the Gross Weigher mode setting (patting bag) is completed, the unlock bag signal is output after this delay. Initial value: 0.5 ; Range: 0.0~99.9 . (Unit: s) |
| | 5. Discharge Delay Timer | During the discharge process, when the weight value of the weighing hopper is less than the Near Zero Band, the delay is started, when delay time is finished, discharge signal is closed. Initial value: 0.5 ; Range: 0.0~99.9 . (Unit: s) |
| | 6. Auto Zero Interval | How many times the packaging process has been completed and then reset once. When entering the running state, the controller is not reset during the first packaging process. Initial value: 0; Range: 0 ~ 99. (Note: This paracontroller is only valid for Net Weigher mode) |
| | 7. Result Checking Mode | Stable value: After the fi-fo is turned off, the weight is stabilized and the set value process is completed. Delay setting: After the fi-fo is turned off, the fixed value is completed after the fixed value is maintained. |

| | | |
|---------------------------|--|--|
| | | Initial value: a stable value. |
| | 8. Result Holding | On/Off is optional; set to “On”, the weight display remains unchanged after the end of the set time, and the weight changes again after the discharge starts. Initial value: off. |
| | 9. Manual Unlock bag I/O | I/O optional, when set to on, running, need manual to control unlock bag. Initial value: off. |
| Adaptive | Used to set adaptive relevant paracontroller | |
| | 1. Adaptive ON/OFF | Adaptive function, automatically adjust the coarse, medium and fine speed of the controller in the running process after the ON/OFF is turned on. Optional ON/OFF, off, double speed, triple speed. Initial value: off. (note: 1. All Remains must be zero before normal use. 2. If Auto Free Fall Correction and the adaptive function are opened at the same time, the Auto Free Fall Correction will be closed forcibly. 3. When the first balance is self-adaptive, the balance body must be stable and the current weight is zero.) |
| | 2. Adaptive Level | The higher the level, the coarser the filling speed, the lower the accuracy. Initial value: 3; Range: 1 ~ 5. |
| | 3. Paracontroller updated ON/OFF | When opened, the change value of Coarse, Medium, Fine Flow Remains will be updated to the value of quantitative paracontroller; When off, quantitative paracontroller values cannot be updated. |
| Auto Free Fall Correction | Used to set Auto Free Fall Correction relevant paracontrollers | |
| | 1. Auto Free Fall Correction | The drop value is the weight value that has not fallen into the measuring hopper after the fine filling signal is turned off. The drop correction is corrected according to the actual blanking value as required. (Note: If the drop correction and adaptive functions are turned on at the same time, the drop correction function is invalid) |
| | 2. Reference Samples PCS | The controller averages the difference of the set number of times as the basis for the drop correction. Initial value: 1 ; Range: 1 to 99 . |
| | 3. Correction Effective Range | The controller averages the difference of the set number of times as the basis for the drop correction. Initial value: 1 ; Range: 1 to 99 . |
| | 4. Correction Percentage | The magnitude of each drop correction. Three ranges are available in 100% , 50% , and 25% . Initial value: 50 % . |
| Over/ | Used to set Over/Under relevant alarm paracontroller | |

| | | |
|------------------------|---|--|
| Under | 1.OVER/UNDER ON/OFF | “On / Off” is optional. When this paracontroller is set to “On”, the quantification process judges the Over/Under. |
| | 2. OVER/UNDER Pause | “On / Off” is optional. When it is set to “On”, when the quantitative process is over or under, controller pauses and waits for the user to process. I/O Module enter Emergency Stop, returns to the stop state, and clear alarm; or I/O Module enter clear alarm, continue quantitative process. |
| | 3. OverLimit Value | In the quantification process, if the weighing value \geq the target value + Over value, it is judged as Over. Initial value: 0 . |
| | 4. Under Limit Value | In the quantification process, if the weighing value \leq target value – Under value, it is judged as Under. Initial value: 0 . |
| | 5. Compensation ON/OFF | Set the Compensation ON/OFF On: Finely add the fill according to the number of fills. Off: Do not replenish when there is a shortfall. |
| | 6. Compensation Times | When the quantitative process is judged to be inferior, the fill is finely added according to this value. Initial value: 1 ; range 1~99 . |
| | 7.Flow-ON Times | When filling the output, the effective time is added finely during an on-off cycle . Initial value : 0.5 ; range: 0.0 to 99.9 . (units) |
| | 8.Flow-OFF times | When filling an output, a pass off the cycle time has no effect on chronic . Initial value : 0.5 ; range: 0.0 to 99.9 . (units) |
| Jog Flow Paracotroller | Used to set manual fine filling related paracontrollers | |
| | 1. Jog Flow ON/OFF | “On / Off” is optional. When set to “On”, the controller is finely added and jogged. Initial value: off. |
| | 2. Jog Flow-ON Timer | When the jog output is finely added, the effective time is added finely during an on-off cycle . Initial value : 0.5 ; range: 0.0 to 9.9 . (unit s) |
| | 3. Jop Flow-on Timer | When the jog output is finely added, the inactive period is finely added during an on-off period . Initial value : 0.5 ; range: 0.0 to 9.9 . (unit s) |

4.2.1 Scale body structure paracontrollers

The controller provides 5 kinds of scale structure, Net Weigher, Gross Weigher, ton bag, valve port and PLC mode. Select different scale structure, the formula paracontrollers show different paracontrollers, the specific scale structure paracontrollers are shown as follows

| | | |
|-----------------------------------|--|--|
| Net Weigher Paracont roller | Used to set the relevant paracontrollers of Net Weigher scale mode | |
| | 1. Filling Combination Times | When there is Net Weigher, the unlock bag is unloaded several times. If it is 0 , the controller discharges directly after the filling is completed without judging whether the pocket is valid. Initial value: 1 ; Range: 0 to 99 . |
| Ton package scale Paracont roller | Used to set the relevant paracontrollers of ton bag scale mode | |
| | 1. Delay time of hanging bag | The bag delay time until the bag is completed . Initial value : 0.5 ; range: 0.0 to 99.9 . (unit s) |
| | 2. Air Blow mode | Before rise delay air blow: air blow output valid , hanger rise output is valid. After rise delay air blow, after hanger output continue hanger rise delay time starts air blow. Initial value:Before Rise delay starts blowing |
| | 3. Blowing timer | Blowing timer Initial value : 0.5 ; range : 0.0~99.9 。 (unit s) |
| | 4. Return valve mode | Close the return valve after filling: after closing the fine fill, the return valve output is invalid. Close return valve after bag unlockning: return valve output is invalid after bag unlockning. Initial value: Close the return valve after filling. |
| | 5. Reset time of hanging bag | When the paracontroller is not set to 0, after filling is completed, the output of the bag is invalid and continues to be valid after this time. Initial value: 0.0;Range: 0.0 ~ 99.9.(unit s) Note: er the reset time of the lifting bag shall be longer than the delay time of the lifting bag before the reset is valid. $\&$ Controller operation first scale needs to manually give a bag signal. $\textcircled{3}$ Paracontroller is set to 0, controller before each start charging, need punching bag signal. |
| | 6. Hanger control mode | Optional automatic rise, automatic fall;Automatic rise, manual down;Manual up, automatic down;Manual up, manual down. Default: auto up, auto down |
| | 7. Delay Before Hanger Rise | This delay is executed after the rising signal is sent. Initial value: 5.0 ; range: 0.0 to 99.9 . (unit s) Note: only valid at Air Drive-unlimit space mode. |
| | 8. Delay Before Hanger Drop | This delay is initiated after the quantitative delay has expired. Initial value: 5.0 ; range: 0.0 to 99.9 . (unit s) Note: only valid at Air Drive-unlimit mode. |
| | 9. Hanger Rise Overtime | The maximum waiting time for the controller hanger in place. Initial value: 5.0 ; range: 0.0 to 99.9 . (unit s) |

| | | |
|--------------------------------|--|--|
| | | Note: only valid at Motor-Dual-Limit/Air Drive-Dual-Limit mode. |
| | 10. Hanger Drop Overtime | The maximum waiting time for the controller hanger to drop . Initial value: 5.0 ; range: 0.0 to 99.9 . (unit s) Note: only valid at Motor-Dual-Limit/Air Drive-Dual-Limit mode. |
| 11. Decoupled up | a. Decoupled up I/O | ON: When is on. OFF: When is off. Initial value:OFF |
| | b. Delay before decoupling | When is on, after decoupling, need to delay the time hanger to rise. Initial value:0.0s Range: 0.0~99.9 (unit s) |
| | c. Decoupling rise time | When the rise I/O is on and the rise support output needs to last for this time after the rise is executed Initial value:0.0s Range: 0.0~99.9 (unit s) |
| | d. Decoupling rise pause time | When the rise I/O is on, and after the decoupling rise is over, it is necessary to wait for the time before descending. Initial value:0.0s Range: 0.0~99.9 (unit s) |
| 12. Uncoupled alarm I/O | a. Uncoupled alarm I/O | ON: Uncoupled alarm I/O is ON. OFF: Uncoupled alarm I/O is OFF Initial value: OFF |
| | b. Decoupling alarm conveyor reversal time | The uncoupled alarm I/O is on. When the uncoupled alarm is complete, the conveyor will perform the reversal immediately for the duration. Initial value:0.0s Range: 0.0~99.9 (unit s) (Set to 0: means the conveyor does not reverse) |
| | c. Weight value of decoupling alarm | The uncoupled alarm I/O is on. If the current weight is greater than the value of the decoupling alarm during the period of decoupling ascending, controller will output the decoupling alarm signal. Initial value:0, range: 0~Maximum range |
| Valve Scale Paracontroller | Used to set the valve scale mode related paracontrollers | |
| | 1. Delay Before Lifting Bag | The delay time before the bag is started at the same time when the unlock bag starts to start . Initial value : 0.5 ; range: 0.0 to 99.9 . (unit s) |
| | 2. Lifting Bag Timer | The time is started after the delay timebefore the bag is lifted , and the bag signal output is valid. After the time is over, the bag signal output is invalid. Initial value : 0.5 ; range: 0.0 to 99.9 . (unit s) |
| | 3. Delay Before Pusing Bag | When the unlock bag start delay starts, the delay time before pushing the bag is started at the same time. |

| | | |
|--------------------|--|---|
| | | Initial value : 0.5 ; range: 0.0 to 99.9 . (unit s) |
| | 4. Pushing Bag Timer | The time is started after the delay time before pushing the bag , and the push bag signal output is valid. After the time is over, the push bag signal output is invalid . Initial value : 0.5 ; range: 0.0 to 99.9 . (unit s) |
| PLC paracontroller | Used to set PLC mode related paracontrollers | |
| | 1. PLC-OverLimit Value | When the weighing value > target value + excess value, the out-of-tolerance output is valid Initial value: 0.00 ; range: 0.00~100.00 . |
| | 2. PLC-UnderLimit Value | When the weighing value < target value - under-difference, the under-output is valid Initial value: 0.00 ; range: 0.00~100.00 . |
| | 3. PLC-UpperLimit Value | When the weighing value > upper limit value, the upper limit output is valid Initial value: 0.00 ; range: 0.00~100.00 . |
| | 4. PLC-LowerLimit Value | When the weighing value is < lower limit, the lower limit output is valid. Initial value: 0.00 ; range: 0.00~100.00 . |

4.3 Weight paracontroller

In the menu interface, click the **【 Weighing 】** menu to enter the current paracontroller item to view and set the attribution paracontroller information.

| Sys&Com | paracontroller | Description |
|-----------------------|------------------------------------|---|
| Weight Paracontroller | 1. Zero Range | The range can be cleared . Initial value: 50 ; Range: 1 to 99 (% of full scale) . |
| | 2. Stable Range / Timer | During the judgment time, the weight change range is within this set value and the controller judges that the scale is stable. Initial value: 2 ; Range: 0 to 99 (d) . First value: 0.3 ; range: 0.1 to 99 . |
| | 3. Zero Track Range / Timer | The weight value is within this range and the controller is automatically cleared. When it is 0 , zero tracking is not performed. Initial value: 0 ; range: 0 to 9 (d) . First Value: 20 ; range: 0.1-9 9.9 . (unit s) |
| | 4. Power-Up Zero | On / off is optional. When it is “on”, the controller will automatically perform the clear operation when the power is turned on (the weight inside the scale bucket meets the clearing range). Initial value: off |
| | 5. A/D Sampling Rate | A/D sampling rate. 120 times / sec, 240 times / sec, 480 times / |

| | | |
|---------------------------------|-------------------------------------|--|
| | | sec, 960 times / sec. Initial value: 240 times / sec. |
| | 6. Stop Digital Filter level | Stop Digital Filter level Initial value: 7 ; range 0~9 . |
| 7. Filter Paracontroller | a. Dynamic Filter | During the bagging process, whether to perform the filter operation ON/OFF and set "On", the following three paracontrollers are valid. Initial value: on. |
| | b. Advance Filter ON/OFF | On/off optional, secondary filtering based on digital filtering. Initial value: off. |
| | c. Filling Filter Level | Filter paracontrollers during filling: 9: The filtering effect is the strongest. Initial value: 4; Range: 0 to 9. |
| | d. Waiting Process Filter | Filter paracontrollers during the setting process: 9: The filtering effect is the strongest. Initial value: 7; Range: 0 to 9. |
| | e. Discharge Process Filter | Filter paracontrollers during unloading: 9: The filtering effect is the strongest. Initial value: 1; Range: 0 to 9. |
| | 8. Running Stable Timeout | Initial value: 0.0 ; range: 0.0 ~ 99.9 .(unit s) |

4.4 System Maintenance

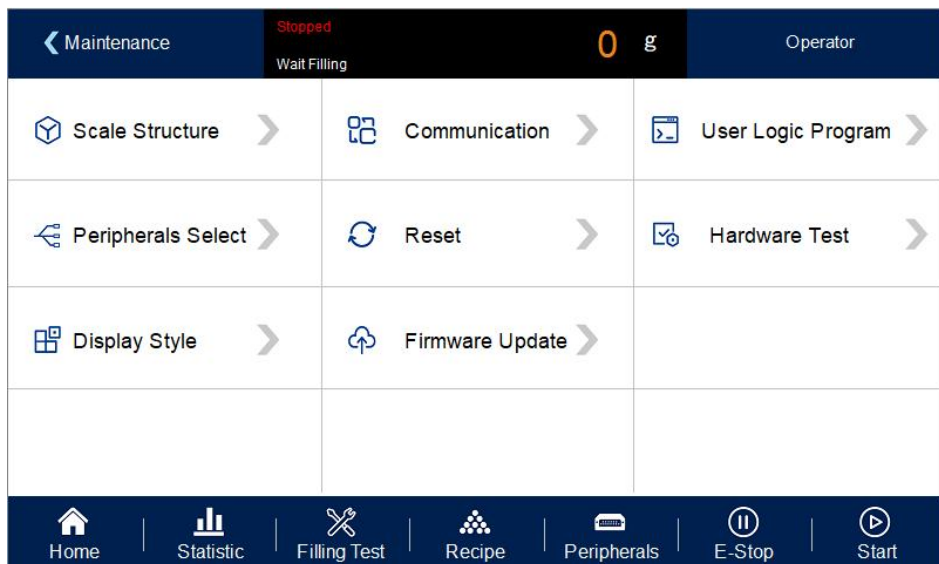

4.4.1 Weigher structure

| paracontroller | Description |
|-----------------------|--|
| 1. Valve Scale | There are Net Weigher / Gross Weigher/ PLC / Jumbo bag / valve port bagging selection available. |

| | | |
|---|--------------------------------------|--|
| | | Initial value: Net Weigher. |
| 2. Net Weigher scale paracontroller setting | a. Working Mode | Optional single scale , interlock A, interlock B. Initial value : single scale . |
| | b. Filling control mode | Single filling/comb filling; Initial value: Comb filling Comb filling: Co-F plus Co-F, Me-F and Fi-F filling port at the same time filling; Add medium and small filling port at the same time filling; Fine time small filling port filling Single filling: Co-F large filling port filling; Me-F Add when the filling port filling; Fi-F small filling port filling. |
| | c. Filling Mode | 0, pneumatic mode; 1 , stepper motor filling; 2 , ordinary motor mode. |
| | d. Lock/Release Mode | 0, pneumatic mode; 1 , stepper motor; 2、 MotorDrive Dual-Limit; 3、 MotorDrive Single-Limit Default: 0 pneumatic |
| | e. Discharge Mode | Initial value: 0 pneumatic discharge; Optional: 0 : pneumatic mode ; 1 : Stepping motor unloading; 2 : motor single limit discharge; 3 : motor double limit discharge; 4 : The motor rotates in one direction. |
| | f. Manual Unlock Bag ON/OFF | Optional on/off; Set to "on", in operation, need to manually control unlock bag. Initial value: off. |
| | g. Realtime Detecting When Discharge | Optional on/off; When "on" is selected, the limit signal is detected in real time; When "off", the limit signal is detected only when filling is started. Initial value: off. (Note: discharge mode is valid in motor mode) |
| 3. Net Weigher scale paracontroller setting | a. Working Mode | Optional single scale , interlock A, interlock B. Initial value: single scale . |
| | b. G/N Mode | Gross /Net Mode. Initial value: Net filling |
| | c. Filling control mode | Single filling/combination filling is optional; Initial value: Combination filling. Combination filling: coarse adding large, medium and small filling port at the same time; Add medium and small filling port at the same time filling; Fine time small filling port filling. Separate filling: coarse adding large filling port filling; Add when the filling port filling; Fine time small filling port filling. |
| | d. Filling Mode | 0, pneumatic mode; 1 , stepper motor filling; 2 , ordinary motor mode. |
| | e. Lock/Release | 0, pneumatic mode; 1 , stepper motor; 2、 MotorDrive Dual-Limit; 3、 MotorDrive Single-Limit |

| | | |
|-------------------------------------|--|--|
| | Mode | Default: 0 pneumatic |
| | f. Unlock bag switch is allowed in filling | Optional on/off; Set to "on", no bucket scale mode, after starting, it is allowed to unlock bags in filling. Set to "off". After starting, it is not allowed to unlock bags in filling Initial value: off. |
| | g. Manual unlock bag ON/OFF | Optional on/off; Set to "on", in operation, need to manually control unlock bag. Initial value: off. |
| | h. Bracket control ON/OFF | Optional on/off; Set to "on". In operation, the movement mode of the bracket needs to be controlled manually. Initial value: off. |
| | i. Bracket movement mode | Optional pneumatic - infinite/electric - double limit/pneumatic - double limit. Initial value: pneumatic - infinite bit. (Note: Paracontrollers can be seen when the support control switch is on) |
| | j. Double scale unlock bag mode | Different Unlock Bag/Simultaneous unlock Bag 1/ Simultaneous unlock Bag 2 are optional. Initial value: unlock bag at different times. unlock bag at different time: unlock bag after finishing packing, when A/B scales are all unlock bag, the controller controls the signal output of conveyor and starts the conveyor. Simultaneously unlock bag 1: in the normal mode, the filling of one scale has been completed and the filling of the other has not been completed. After the completion of the other scale, both scales are losing bag at the same time. If a scale has finished filling, the other scale is not in the bag (filling) state, then do not wait for another scale, this scale directly unlock bag. At the same time, unlock bag 2: for the coarse mode, this mode defaults to scale A in the front and scale B in the back. After filling, scale A will not judge whether B is finished or not, and will unlock the bag directly. After the completion of filling, B should judge whether A is in the state of bag clamping (filling). If A is filling, B should wait for A to finish adding and unlock the bag. If A is not filling, B does not have to wait to unlock the bag. (Note: the working mode is interlocking scale A and interlocking scale B, paracontrollers can be seen.) |
| | k. allow unlock bag when filling switch | Optional on/off; When set to "on", Gross Weigher, controller filling allow manual unlock bag, after unlock bag controller re-enter to filling wait mode. Initial value: off. |
| 4. Jumbo Bag paracontroller setting | a. G/N mode | Gross /Net Mode. Initial value: Net filling |
| | b. Filling control mode | Single filling/combination filling is optional; Initial value: Combination filling. Combination filling: coarse adding large, medium and small filling port at the same time; Add medium and small filling |

| | | |
|--|--|---|
| | | port at the same time filling; Fine time small filling port filling. Separate filling: coarse adding large filling port filling; Add when the filling port filling; Fine time small filling port filling. |
| | c. Filling Mode | 0, pneumatic mode; 1, stepper motor filling; 2, ordinary motor mode. |
| | d. Lock/Release Mode | 0, pneumatic mode; 1, stepper motor; 2, MotorDrive Dual-Limit; 3, MotorDrive Single-Limit Default: 0 pneumatic |
| | e. Manual unlock bag ON/OFF | Optional on/off; Set to "on", in operation, need to manually control unlock bag. Initial value: off. |
| | f. Bracket movement mode | Optional pneumatic - infinite/electric - double limit/pneumatic - double limit. Initial value: pneumatic - infinite bit. (Note: Paracontrollers can be seen when the support control switch is on) |
| | g. Hanger bag movement control ON/OFF | Optional on/off; Set to "open", ton bag scale mode, after starting, allowed to lift bag, not allowed to take off the bag. Initial value: off. |
| | h. Hanger bag inverse logic ON/OFF | Optional on/off; Set to "on", in the ton bag scale mode, when the bag output is effective, the output of switching quantity is invalid; when the bag output is invalid, the output of switching quantity is effective. Initial value: off. |
| | i. Tare weight detection switch | Optional on/off; When set to "on", the controller will return to the stop state without filling to a fixed value in the operation of the controller. When it is started again, it does not need to remove the skin and start filling directly. Note: This function will only record the tare value when the current weight is greater than 0 and it is started again. Initial value: off. |
| 5. Valve scale paracontroller setting | a. G/N mode | Gross /Net Mode. Initial value: Net filling |
| | b. Filling control mode | Single filling/Comb filling; Initial value: Comb filling Combination filling: coarse adding large, medium and small filling port at the same time; Add medium and small filling port at the same time filling; Fine time small filling port filling. Separate filling: coarse adding large filling port filling; Add when the filling port filling; Fine time small filling port filling. |
| | c. Filling Mode | 0, pneumatic mode; 1, stepper motor filling; 2, ordinary motor mode. |
| | d. Lock/Release Mode | 0, pneumatic mode; 1, stepper motor; 2, MotorDrive Dual-Limit; 3, MotorDrive Single-Limit Default: 0 pneumatic |
| | e. Manual unlock bag | Optional on/off; Set to "on", in operation, need to manually control unlock bag. |

| | | |
|--|--------|---------------------|
| | ON/OFF | Initial value: off. |
|--|--------|---------------------|

4.4.2 Communication Setting

GM9907 Two serial communication interfaces can be provided. See Section 2.5 for the definition of serial port output; correct setting of port paracontrollers can be used for communication.

| Sys&Com | paracontroller | Description |
|---|----------------------------|---|
| Serial port (Serial port 1 (232) 、 Serial port 2 (485)) | 1. Communication ID | Initial value: 1 ; 1 ~ 9 9 optional. |
| | 2. Communication Mode | Initial value: Modbus-RTU . Modbus-RTU / Print / Continuous Mode / MD-R (compatible with version 01.) is optional. |
| | 3. Baudrate | Initial value: 38400 ; 9600/19200/38400/57600/115200 optional. |
| | 4. Data Format | Initial value: 8-E-1 (8 -bit data bit -even parity - 1 stop bit) ; 8-E-1/8-N-1/7-E-1/7-N-1 is optional. |
| | 5. Modbus Dword Format | Modbus communication display mode: Initial value: AB-CD (high word first); AB-CD (high word first) / CD-AB (low word first) optional. |
| Ethernet Interface | 1. Communication Mode | Fix: Modbus-TCP . |
| | 2. modbus-TCP Dword Format | Initial value AB-CD . Range: AB-CD (high word first) CD-AB (low word first) |
| | 3. Server Port | Initial value : 502 Range: 1~65535 |
| | 4. IP | Initial value : 192 Range: 0~255 |
| | | Initial value : 168 Range: 0~255 |
| | | Initial value : 101 Range: 0~255 |
| | | Initial value : 246 Range: 0~255 |
| 5. MAC | BC.66.41.9x.xx.xx . | |
| Print paracontroller rs | 1. Auto Print | On/Off is optional; when “On” is selected, the package result will be printed out automatically every time the package is completed (the serial port should be selected as “Print”). Initial value: off. |
| | 2. Printer Format | Initial value: 24 columns of printing; 24 columns of printing / 32 columns of printing. |
| | 3. Printing Language | Initial value: Chinese; Chinese / English optional. |
| | 4. Printing Line Nos. | The number of lines after the print is completed. |

| | | |
|--|--|--|
| | | Initial value: 3 ; 0~9 optional. |
|--|--|--|

4.4.3 User Logic

Auxiliary logic programming function, up to 6 sets of auxiliary logic trigger signals can be defined, and the effective time and output port after the auxiliary logic signal is triggered can be set. The simple logic signal output can be configured to control other auxiliary devices, and 6 sets of auxiliary logic signals. They can also control each other.

Under the auxiliary logic programming interface:

| Auxiliary logic(1~6) Programming paracontroller | paracontroller | Description |
|---|---------------------------------|--|
| 1.Logic Type (1-6) | CLOSE | The type of auxiliary logic programming signal is selected based on the logic to be implemented. |
| | Delay ON | |
| | Delay Off | |
| | Delay ON And OFF | |
| | OFF-ON,Edge Trigger | |
| | ON-OFF,Edge Trigger | |
| 2. User Logic (1-6) Trigger Define | Self-Define Trigger (default) | After setting any of the 1~ 12 channels as the trigger signal, the input port will be fixed as the trigger signal. |
| | IN port 1~12 | Set any of the 1~ 12 input ports as the trigger signal, then the input can be either the trigger signal or the function signal of the input port. |
| | Output definition | After the trigger signal is set to “an internal function signal”, the trigger output is performed according to the function signal. |
| | > = or < = weight Value Trigger | After the trigger condition is set , the current weight value is compared with the set weight threshold , and theoutput is triggered when the condition is met . |
| 3. Logic(1-6) Trigger Input Port | IN1~12 | Initial value: no definition. Select the digital input port corresponding to the function signal. The input port “ 0 is not defined” means that the function is not defined. |
| 4. Logic(1-6) Output Port | OUT1~16 | Initial value: no definition. Select the digital output port corresponding to the function signal. The output port “ 0 is not defined”means that the function is not defined. |

| | | |
|----------------------------------|----------------|---|
| 5. Logic(1-6) Delay ON Timer | Unit s | Initial value: 0.0 ; Range: 0.0~99.9 . After the trigger signal is valid, the logic output signal is valid after the delay. |
| 6. Logic(1-6) Delay OFF Timer | Unit s | Initial value: 0.0 ; Range: 0.0~99.9 . After the trigger signal is invalid, the logic output signal will be invalid after the delay. |
| 7. Logic(1-6) Output ON Timer | Unit s | Initial value: 0.0 ; Range: 0.0~99.9 . The duration after the logic output signal is valid, and becomes invalid after the end of the time. |
| 8. Logic(1-6) Trigger weight | Unit KG | Initial value: 0.0 0 ; Range: 0.0~ 100.00 . Set the weight value, the current weight and the threshold weight comparison , and trigger when the weight value trigger condition is met .(When the trigger select "> =", or "<=weight value" valid). |

4.4.3.1 Delay on

● ● When the delay is turned on [Custom Input Port Trigger], the operation is as follows:

1. Set paracontrollers and ON/OFF quantity: type selection [delay turn-on], trigger signal If [Custom trigger input] is selected, the trigger input port is defined as " 1 " (you can see that the ON/OFF input port 1 is displayed as "auxiliary logic" Trigger input 1), the logic output port is defined as " 1 " (you can see that the digital output port 1 is displayed as "auxiliary logic output 1 "), and the [delay on time] is set to 2 seconds.

2. Execute operation: make the trigger signal input 1 valid, start the delay delay on time, and continue to be valid until the delay on time 2s ends, the logic output signal port 1 output is valid until the trigger signal input 1 is invalid, the logic output Signal port 1 also becomes invalid. See the timing diagram below:

● When the delay is turned on [fixed input port trigger], the operation is as follows:

1. Set paracontrollers and ON/OFF quantity: trigger signal to select "input port 1 " (you can see that the digital input port 1 is displayed as "the original unchanged definition", assuming the original definition is start, the function of input port 1 can be "start" "It can also be "signal trigger"), the logic output port is defined as 1 (the ON/OFF output port 1 can be seen as "auxiliary logic output 1 "), and the [delay on time] is set to 2 seconds.

2. Execution operation: make the trigger signal input 1 valid (starting is also valid, the controller running output is valid), start the delay-on time, and remain valid until the delay-on time is 2s , the logic output signal port 1 output is valid. Until the trigger signal input 1 is invalid, the logic output signal port 1 also becomes invalid. The controller will continue to run until an emergency stop signal is given.

● When the delay is turned on [ON/OFF output definition trigger], the operation is as

follows:

1. Set paracontrollers and ON/OFF quantity: trigger signal select "Run" (ON/OFF output can define or not define running signal), logic output port is defined as 1 (can see that ON/OFF output port 1 is displayed as auxiliary logic output 1), [Delayed On Time] is set for 2 seconds.

2. Execution operation: After the external input "start", when the "run" output signal is valid, it starts to go [delayed on time], and remains valid until the end of the delay on time 2s , the output of the logic output signal port 1 is valid. The logic output signal port 1 becomes invalid until the "Emergency stop or pause" is valid and the "Run" output signal is invalid.

● When the delay is turned on [\geq or \leq weight value trigger], the operation is as follows:

1. Set the corresponding threshold weight, the logic output port is defined as 1 (you can see that the ON/OFF output port 1 is displayed as the auxiliary logic output 1), and the [delayed on time] is set to 2 seconds.

2. Execution operation: current weight value \geq or \leq logic 1 threshold weight is valid when setting value , start to go [delay on time], it is valid until the end of delay on time 2s , logic output signal port 1 The output is valid until the current weight $<$ or $>$ logic 1 threshold weight setting value is invalid for logic output signal port 1 .

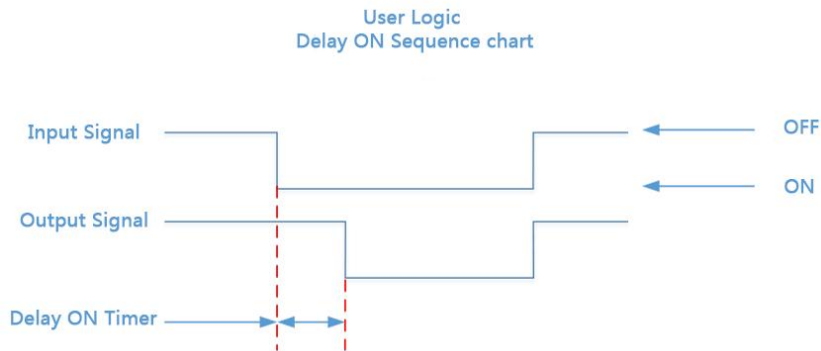

4.4.3.2 Delay off

Related paracontrollers: Type selection [delay disconnect], select [trigger signal], set [trigger input port], [logic output port definition], [delay disconnect time]. Operation Reference "3.8 .1-Delay."Its output function is shown below:

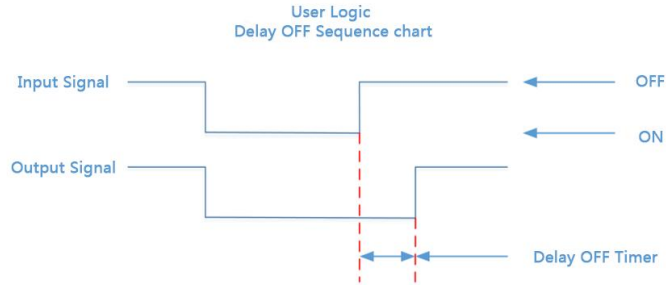

4.4.3.3 Delay on and delay off

Related paracontrollers: Type selection [delay on and delay off], select [trigger signal], set [trigger input port], [logic output port definition], [delay on time], [delayed off time] . Operation Reference "4.4.3.1-Delay." Its output function is shown below:

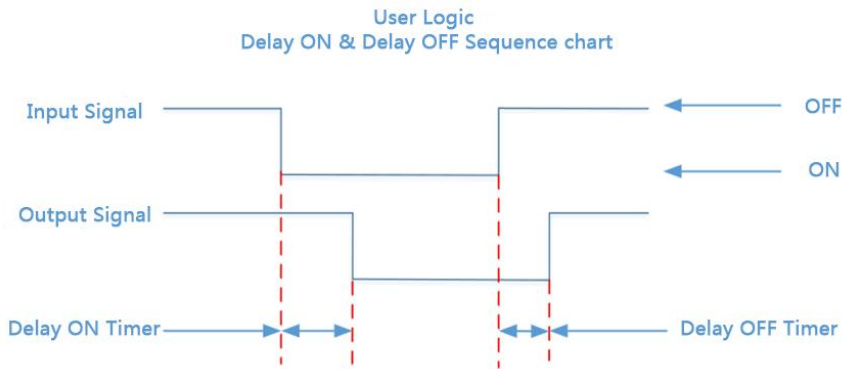

4.4.3.4 Invalid - valid edge triggered

Related paracontrollers: Type selection [invalid - valid edge trigger], select [trigger signal], set [trigger input port], [logic output port definition], [delay on time]. Operation Reference "3.8 .1-Delay." Its output function is shown below:

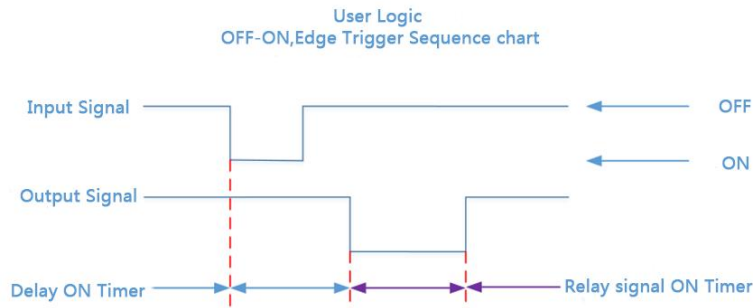

4.4.3.5 Valid - invalid edge trigger

Related paracontrollers: Type selection [valid - invalid edge trigger], select [trigger signal],

set [trigger input port], [logic output port definition], [delay on time]. Operation Reference "3.8 .1-Delay." Its output function is shown below:

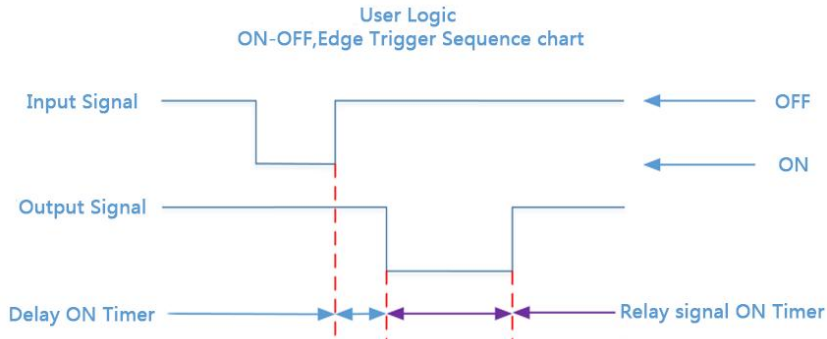

4.4.4 Peripheral paracontrollers

This paracontroller sets the switch of controller peripheral. If set on, peripheral paracontrollers of the main interface can be set. Refer to Chapter 4.5 for specific peripheral paracontrollers.

| Peripherals | paracontroller | Description |
|-------------|-----------------------|--|
| Peripherals | 1. Patting Mode | Bag mode selection; Initial value: Do not pat bag. Optional: Net Weigher mode: the bag is not available after the bag / set value; No jogging mode: Sign bag / bags after setting Sign / addition in the film bag /bags jog plus values were correctly predicted; T packet mode: Sign bag / bags after setting Sign / addition in the film bag /bags jog plus values were correctly predicted; Port mode: Sign bag / bags after setting Sign / addition in the film bag / bags jog plus values were correctly predicted; PLC mode: Sign bag / bags after setting Sign / addition in the film bag / bags jog plus values were correctly predicted; |
| | Sewing machine ON/OFF | Whether to turn on the function of bale sewing machine.Optional on and off. When open, the peripheral can start to sew the bag, and the paracontrollers of the sew machine can be set. |
| | Conveyor mode | Selection of conveyor mode: Initial value: Off With bucket/without bucket/valve port scale mode: closed /1 level conveyor optional; |

| | | |
|--|-------------------------------|---|
| | | Ton bales scale mode: closed /1 level conveyor /2 level conveyor /3 level conveyor optional. |
| | Coding Device ON/OFF | Whether to enable the coding function. On and off are optional. When on, the peripheral starts coding function and the coding paracontrollers can be set. |
| | Discharge patting Switch | Whether to open the Discharge patting function. Optional on and off. When on, the external device opens the Discharge patting function, and the Discharge patting paracontrollers can be set. |
| | Auxiliary Pulse ON/OFF | Whether to enable auxiliary pulse function. On and off are optional. When on, this function is enabled by peripheral and auxiliary pulse paracontrollers can be set. |
| | Fill/Discharge overtime alarm | Whether to turn on the timeout alarm function of Fill/Discharge . On and off are optional. When on, this function is enabled by peripheral and timeout alarm paracontroller can be set. |

4.4.5 Factory reset

System Engineers can restore and backup data through the recovery factory in **【System Maintenance】** .

| | | |
|---------------|---------------------------------------|--|
| Factory reset | 1. Reset All (Except calibration) | Click this item to restore all paracontrollers of the controller (except calibration paracontrollers) to factory setting values. |
| | 2. Reset All | Click this to restore all the paracontroller values of the controller to the factory settings. |
| | 3. Reset Calibration Paracontroller | Click this to restore the calibration scale paracontroller value to the factory setting value. |
| | 4. Reset weight paracontroller | Click this to reset weight and scale body paracontroller as factory setting |
| | 5. Reset Recipe Paracontroller | Click this to restore the recipe paracontroller value to the factory setting. |
| | 6. Reset Communication Paracontroller | Click this item to restore communication setting paracontroller value is factory setting value. |
| | 7. Reset Peripherals Paracontroller | Click this item to restore peripheral paracontroller values and peripheral switch to factory setting values. |
| | 8. Reset Motor Paracontroller | Click this item to restore motor paracontroller value to factory setting value. |
| | 9. Reset I/O Function | Click this item to restore I/O Function to factory setting value. |
| | 10. Reset logic edit paracontroller | Click this item to restore logic edit paracontroller to factory setting value. |

| | | |
|--|--|---|
| | 11. Execute paracontroller backup | Click controller to backup the current paracontroller setting values. |
| | 12. Recovery From Backup data | Click controller to restore the paracontroller value to the most recent backup value. |
| | 13. Delete paracontroller Backup | Click controller to delete the backup paracontrollers. |

4.4.6 Hardware setting

This can check whether the output and input interfaces of the controller are normally connected with external devices through IO test. Before I/O test, I/O test switch on, and then I/O test.

Output port test: under the IO test interface, start the output test, that is, after clicking the corresponding output port button, the color of the interface port will light up. The output state of the corresponding external connection should be valid. If it is invalid, it means the connection is abnormal.

Input port test: in the IO test interface, when the external input signal is valid, the corresponding input port color under the interface will light up to green. When the external input is valid, the interface has no response, indicating abnormal connection. Check the power supply input and wiring of the I/O Module.

4.4.7 Style setting

| | | |
|---------------|--|--|
| Style setting | 1. Screen Saver Time | You can set the time when the screen is off. Default: Never; Optional never /60 seconds /10 minutes /30 seconds /5 minutes /30 minutes |
| | 2. Screen Saver | Data rendering style, quick debugging style is optional. Default: data rendering style. |
| | 3. Permission Cancel timer | Set Permission Cancel time |
| | 4. Multi-user login function ON/OFF | Enable multi-user login function, can set the number of users login |
| | 5. Number of users logged in | The multi-user login switch is turned on to set the number of users logging in |

4.5 Peripheral paracontrollers

Click the **【 Peripheral 】** menu bar in the main interface (Note: the corresponding peripheral switch in system maintenance paracontrollers is turned on, and the corresponding peripheral paracontrollers can only be seen)

| Peripherals | paracontroller | Description |
|-------------|----------------|-------------|
|-------------|----------------|-------------|

| | | |
|-------------------------------|---------------------------------|--|
| Patting Paracont roller | 1. Patting Mode | Select according to the pat bag mode of the system maintenance peripheral switch |
| | 2. Patting ON Timer | During the on-off cycle of the bag, the bag output valid time. Initial value: 0.5 ; Range: 0.0~99.9 . (unit s) |
| | 3. Patting OFF Timer | In the on-off cycle of the bag, the bag output invalid time. Initial value: 0.5 ; Range : 0.0~99.9 . (unit s) |
| | 4. Patting Start Delay Timer | After the bag is started, the bag output is valid after this delay time. Initial value: 0.5 ; Range : 0.0~99.9 . (units) |
| | 5. Patting Times(Waiting) | After the fixed value, the number of times the bag is set, the number of times the bag is taken. Initial value: 4 ; Range: 0~99 . |
| | 6. Extra ON Timer | Generally used in the anchor bag function. After all the bags are finished, the additional bag output is added once, and the effective time is set to the time. The invalid time is “the bag invalid time” . Initial value: 0 .0 . Range: 0.0~99.9 . (units) (Note: the time when the unlock bag is delayed is not changed, or the “ lead bag delay” time is started after all the original bag output ends effectively , that is, the effective time of the extra bag output is started after the bag output valid time is over. To achieve the abutment function, the time and the “unlock bag delay” time should be set appropriately, but the time setting should generally be greater than the “unlock bag delay”, that is, the bag should be unlocked first, then the bag mechanism will rise again) . |
| | 7. Pat bag start up weight 1 | Under without hopper, ton bag, valve scale mode are valid, choose Filling medium pat bag mode, current weight must \geq pat bag start up weight, starts pat bag. Initial value: 0 ; Range: 0 ~ Maximum range |
| | 8. Start-Up Weight 2 | The current weight must be greater than or equal to the starting weight of the racket bag 2 to start the racket bag. Initial value: 0; Range: 0~ maximum range |
| | 9. Start-Up Weight 3 | The current weight must be greater than or equal to the starting weight of the racket bag 3 to start the racket bag. Initial value: 0; Range: 0~ maximum range. |
| | 10. Patting Times(Filling) 1 | Setting paracontroller for the number of petting bags in filling, if set to 0, no petting bags. Note: when the filling process enters the fine filling, force the end of the filling bag, no matter whether the filling bag is completed or not. (After entering the small throw, do not shoot the bag in the middle of filling) |

| | | |
|-----------------------------------|---|---|
| | | The number of raps corresponding to the starting weight of the bag 1 Initial value: 0; Range: 0~99. |
| | 11. Patting Times(Filling) 2 | The number of raps corresponding to the starting weight of the bag 2 Initial value: 0; Range: 0~99. |
| | 12. Patting Times(Filling) 3 | The number of raps corresponding to the starting weight of the bag 3 Initial value: 0; Range: 0~99. |
| | 13. Patting output interface | This can be used to quickly define the output of the patting switching I/O module. |
| Sewing | 1. Sewing ON/OFF | The peripheral switch is set to "on" to turn on the function of the bagging machine |
| | 2. Sewing Start Delay Timer | After the sewing machine start ON/OFF is activated, the sewing machine delay time is started . Initial value: 0.5 . Range: 0.0~99.9 . (unit s) |
| | 3. Sewing ON Timer | After the delay time has elapsed, the sewing machine output is started and the sewing machine output time is continuously output . Initial value: 4.0 . Range: 0.0~99.9 . (unit s) |
| | 4. Cutter ON Timer | After the start up of the cutter, start the output of the cutter and continue the output time of the cutter. Initial value: 0.5.Range: 0.0~99.9.(unit s) |
| | 5.Sewing machine anti-shake time | Prevent the abnormal operation of the sewing caused by the photoelectric jitter of the sewing starting.During the de-shaking time, the photoelectric jitter of the baling, but the output of the baling is still valid at this time. Initial value: 0.3.Range: 0.0~99.9.(unit s) |
| | 6. Cutter ON Timer | After the start up of the cutter, start the output of the cutter and continue the output time of the cutter. Initial value: 0.5.Range: 0.0~99.9.(unit s) |
| | 7. Cutter output valid timer | After the start of the cutter, start the output of the cutter and continue to output the valid time. Initial value: 0.5.Range: 0.0~99.9.(unit s) |
| | 8. IO function define | This can be used to quickly define the input port of the start and emergency stop of the bagging machine, and the output port of the bagging machine and the thread cutting machine. |
| Discharge patting paracont roller | 1.Discharge patting Switch | The peripheral switch is set to "on" to open the Discharge patting function |
| | 2. Discharge valid time | When the fixed value hold time is, the period from the start of output discharge signal to the start of discharge delay after discharge is completed is the effective discharge time.When the unloading duration exceeds this time, it is considered abnormal and the unloading vibration action is started |

| | | |
|--------------------------------|--|---|
| | | Initial value: 2.0 ; range 0.0~9.9 。 (Unit s) |
| | 3. Discharge ON Timer | Initial value: 0.5 ; range 0.0~9.9 (Unit s) |
| | 4. Discharge patting OFF Timer | Initial value: 0.5 ; range 0.0~9.9 (Unit s) |
| | 5. Discharge patting Times | Initial value: 10 ; range 0~99 |
| | 6. Discharge patting output port | This can be used to quickly define the discharge vibration output port. |
| Conveyor paracontroller | 1. Conveyor mode | When the peripheral switch selects the 1 level conveyor /2 level conveyor /3 level conveyor, the output function of the conveyor is turned on |
| | 2. Conveyor 1 Start Delay Timer | After the delay of the unlock bag, the controller judges that the conveyor is started. Initial value: 0.5 ; range: 0~99.9 . (unit s) |
| | 3. Conveyor 1 Running Timer | Conveyor runtime setting. Initial value: 4.0 ; range: 0~99.9 . (unit s) |
| | 4. Conveyor 2/3 Max running Timer | Conveyor 2/3 runtime setting. (Note: In the Jumbo Bag mode, the paracontrollers of the conveyor level 2 or level 3 can only be seen when the conveyor level is turned on) Initial value: 30.0; range: 0~99.9。 (unit s) |
| | 5. IO function define | Through this, the I/O module related to conveyor can be quickly defined, including manual conveyor 1 forward rotation, manual conveyor 1 reverse, conveyor 2 limit, conveyor 3 limit input port, conveyor 1, conveyor 1 reverse, conveyor 2, conveyor 3 output port |
| Coding Paracontroller | 1. Coding Device ON/OFF | On/off optional; set to "on", the controller has a code output function; Initial value : off. |
| | 2. Coding Start Delay Timer | The pocket is completed, and the output is valid after the delay; Initial value: 0.5 ; Range: 0.0~99.9 . (units) |
| | 3. Coding Duration Timer | The effective time of coding; Initial value: 0.5 ; Range: 0.0~99.9 . (units) |
| | 4. Not Allow Fill/Discharge When Coding | On/Off is optional; set to "On", it is not allowed to start filling (no bucket mode) output or unloading (with bucket mode) output during coding . Initial value : off. |
| Auxiliary pulse paracontroller | 1. Auxiliary pulse ON/OFF | The peripheral ON/OFF is set to "on" to enable the auxiliary pulse function |
| | 2. Auxiliary pulse mode | Auxiliary pulse mode 1~4 can be selected according to requirements 0: Pulse mode;1: Level mode. Initial value: 0: Pulse mode. |
| | 3. Auxiliary Pulse | Auxiliary Pulse 1 Execute Total Timer. If 0, keeps |

| | | |
|----------------|---|--|
| | 1 Execute Total Timer | running. Initial value : 0 ; range : 0.0~999.9 .(unit s) |
| | 4. Auxiliary Pulse 1 On Timer | Initial value : 10.0 ; range : 0.0~999.9 .(unit s) |
| | 5. Auxiliary Pulse 1 Off Timer | Initial value : 10.0 ; range : 0.0~999.9 .(unit s) |
| | 6. Auxiliary Pulse 2 Execute Total Timer | Auxiliary Pulse 2 Execute Total Timer. If 0, keeps running. Initial value : 0 ; range : 0.0~999.9 .(unit s) |
| | 7. Auxiliary Pulse 2 On Timer | Initial value : 10.0 ; range : 0.0~999.9 .(unit s) |
| | 8. Auxiliary Pulse 2 Off Timer | Initial value : 10.0 ; range : 0.0~999.9 .(unit s) |
| | 9. Auxiliary Pulse 3 Execute Total Timer | Auxiliary Pulse 3 Execute Total Timer. If 0, keeps running. Initial value : 0 ; range : 0.0~999.9 .(unit s) |
| | 10. Auxiliary Pulse 3 On Timer | Initial value : 10.0 ; range : 0.0~999.9 .(unit s) |
| | 11. Auxiliary Pulse 3 Off Timer | Initial value : 10.0 ; range : 0.0~999.9 .(unit s) |
| | 12. Auxiliary Pulse 4 Execute Total Timer | Auxiliary Pulse 4 Execute Total Timer. If 0, keeps running. Initial value : 0 ; range : 0.0~999.9 .(unit s) |
| | 13. Auxiliary Pulse 4 On Timer | Initial value : 10.0 ; range : 0.0~999.9 .(unit s) |
| | 14. Auxiliary Pulse 4 Off Timer | Initial value : 10.0 ; range : 0.0~999.9 .(unit s) |
| Overtime alarm | 1. Overtime Checking ON/OFF | Add and discharge timeout judgment ON/OFF. After the opening , the loading and unloading timeout judgment is performed in the running state . Initial value : off . |
| | 2 Coarse Flow Overtime | In the running state, after the coarse output exceeds the time, the output timeout alarm is issued and the machine stops. Initial value : 5.0 ; range 0.0~99.9 . (units) |
| | 3. Medium Flow Overtime | In the running state, after the output is over this time, the output timeout alarm is issued and the machine stops. Initial value : 5.0 ; range 0.0~99.9 . (units) |
| | 4. Manual Fine Overtime | In the running state, after the fine output exceeds the time, the output timeout alarm is issued and the machine stops. Initial value : 5.0 ; range : 0.0~99.9 .(unit s) |

| | | |
|--|------------------------------|---|
| | 5. Discharge Overtime | In the running state, after the discharge output exceeds this time, the output timeout alarm and stop. Initial value : 5.0 ; range : 0.0~99.9 .(unit s) |
|--|------------------------------|---|

4.6 Motor paracontroller

When the scale structure is Net Weigher, Gross Weigher, ton bag and valve port scale structure, the "filling mode", "Lock/Release Mode " and "discharge mode" of the system maintenance paracontroller scale property are set to the motor mode, and the following paracontrollers can be seen.

- ◆ Enter the interface of motor paracontrollers from [Menu] - [Motor].
- ◆ The unit number on the right side can be switched.

| Motor | paracontroller | Description | |
|-------------------------------|---|---|--|
| Filling paracont roller | 1. Filling mode | Initial value: pneumatic filling; Optional: 0 , pneumatic mode; 1 , stepper motor filling; 2 , ordinary motor mode. | |
| | 2. Closing in place signal type | 0 when the signal is valid in place (when the input is valid, the door is considered to be in place). 1 the signal is invalid in place (when the input is invalid, the door is considered to be in place). | |
| | 3. Current Filler Motor Cfg ID | Set Current Filler Motor Cfg ID | |
| | 4. Filler Gate Close Overtime | Default: 4.0 , Range: 0.0~99.9 (Unit: s) | |
| | 5. Step Motor Drive paracontroller setting | a. Filling frequency | Default: 12000 , Range: 1~50000 (Unit: Hz) |
| | | b. Fi-f pulse | Default: 1800 , Range: 1~60000 |
| | | c.Me-f pulse | Default: 4300 , Range: 1~60000 |
| | | d.Fa-f pulse | Default: 7750 , Range: 1~60000 |
| | | e. Manual Fine Flow, Manual Medium Flow, Manual Coarse Flow | Test shortcut key, used to check the device opening status, to quickly adjust the pulse number |
| | | f. Start Frequency | Filling motor Start Frequency. Default: 2000 Range: 0~50000 . (Unit: Hz) (This value cannot bigger than the filling motor frequency) |
| | | g. ACC Time | Filling motor ACC Time Default: 100 , Range: 0~9999 (Unit ms) |
| h. DEC Time | | Filling motor DEC Time Default: 50 , Range: 0~9999 . (Unit ms) | |

| | | | |
|--|--|---|---|
| | | i. IO function define | Options: a) State of filling door opening direction signal: 0 When the signal is invalid, it is the direction of the door opening: when the filling door opening action, the output of the rotation direction signal of the filling stepper motor is invalid, and the output of the direction signal is effective when the closing action; 1 When the signal is effective, it is the direction of opening the door: when the filling step motor is opening the door, the output of the rotation direction signal of the filling step motor is effective, and the output of the direction signal of the closing action is invalid. b) Quickly define the input port, filling direction signal and filling pulse output port I/O module in place of filling and closing |
| | | j. Power back to zero frequency | When the power is off and restarted, the filling motor returns to the origin with this frequency. Initial value: 2000 , Range: 0~50000. (Unit Hz) |
| | 6. Filling normal motor paracontroller setting | a. Fi-F timer | The time required to open the filling door to the Fi-F position. Initial value: 0.2 , Range: 0~99.99 (Unit s) |
| | | b Me-F timer | The time required to open the filling door to the Me-F position. Default: 0.4 , Range: 0~99.99 (Unit s) |
| | | c.Fa-F timer | The time required to open the filling door to the Fa-F position. Default: 0.8 , Range: 0~99.99 (Unit s) |
| | | d. Manual Fine Flow, Manual Medium Flow, Manual Coarse Flow | Test shortcut key, used to check the state of the equipment, to quickly adjust the motor coarse, fine and add time. |
| | | e. Filling door close in place input port | Quickly set the input/output port of filling related I/O module |
| | | f. Filling door output port | |
| | | g Output port of filling door | |
| | Bag Clutch | 3. Step motor | a. Lock/Release |

| | | | |
|-----------------|---------------------------------|-----------------------------|--|
| Paracont roller | Lock/Release bag paracontroller | bag mode | |
| | | b. Release bag signal mode | 0 In place when the signal is effective (when the input is effective, the door is considered to be in place) 1 In place when the signal is invalid (when the input is invalid, the door is considered to be in place) |
| | | c. Lock bag signal mode | Default: 3.0 , Range: 0.0~99.9 (Unit s) |
| | | d. Clutch Lock Frequency | Default: 30000 , Range: 1~50000 (Unit:Hz) |
| | | e. Clutch Release Frequency | Default: 20000 , Range: 1~50000 (Unit Hz) |
| | | f. Lock bag steps | Default: 12000 , Range: 1~60000 (Unit Hz) |
| | | g. Start Frequency | Default: 2000 , Range: 0~50000 (Unit Hz) (this value can't bigger than clutch bag frequency) |
| | | h. ACC Time | Default: 200 , Range: 0.0~9999 (Unit ms) |
| | | i. DEC Time | Default: 50 , Range: 0.0~9999 (Unit ms) |
| | | j. IO function define | Optional A) Bag direction signal state: 0 direction signal output is invalid when the bag is clamped: when the bag unlockning mechanism clamps the bag, the rotation direction signal output of the stepping motor of the bag unlockning mechanism is invalid, but the direction signal output is effective when the bag unlockning mechanism clamps the bag; 1. Effectiveness of direction signal output when the bag is clamped: when the bag is clamped unlock, the rotation direction signal output of the stepper motor of the bag is effective, but when the bag is clamped unlock, the direction signal output is invalid. B) Quickly define the switching quantity of input port, direction signal and pulse output port of unlock bag in place. |
| | | k. Power on zero frequency | When the power is cut off and restarted, the clutch motor returns to the origin at this frequency. Initial value: 2000 , range: 0~50000 . (Unit Hz) |
| | | l. Bag Clutch button | The shortcut button is used to detect the condition of the bag clutch |
| | 4. | a. Lock/Release | MotorDrive Dual-Limit |

| | | |
|--------------------------------------|--|--|
| MotorDrive Dual-Limit Paracontroller | se Mode | |
| | b. Clutch Limit Signal Type | 0 : Place in place when the signal is effective (when the input is effective, the door is considered to be in place) 1 : Place in place when the signal is invalid (when the input is invalid, the door is considered to be in place) |
| | c. Bag Release Overtime | Default: 3.0 , range: 0.0~99.9 (Units) |
| | d. Bag Lock Overtime | Default: 3.0 , range: 0.0~99.9 (Units) |
| | e. Bag Locked Input | Quick setting of motor double limit lock unlock bag related switch input and output ports. |
| | f. Bag Released Input | |
| | g. Bag Locked Output | |
| | h. Bag Released Output | |
| | i. Bag Clutch button | The shortcut button of Bag Clutch |
| | 5. MotorDrive Single-Limit Bag Clutch Paracontroller | a. Bag Clutch mode |
| b. Clutch Limit Signal Type | | 0 when the signal is valid in place (when the input is valid, the door is considered to be in place). 1 the signal is invalid in place (when the input is invalid, the door is considered to be in place). |
| c. Bag Lock Overtime | | Default: 3.0 , range: 0.0~99.9 (Unit s) |
| d. Bag Release valid time | | Normal motor release bag valid time Default: 0.5 , range: 0~99.99 (Units) |
| e. Clutch bag button | | Shortcut key for clutch bag |
| f. Bag Locked Input | | Quick setting of motor single limit clutch bag related switch input and output ports. |
| g. Bag Locked Output | | |
| h. Bag Released Output | | |

| | | | |
|---|---|--|---|
| Discharge Paracontroller (Net Weigher mode) | 1. Step motor Discharge Paracontroller setting | a. discharge mode | Step motor |
| | | b. DISC Gate Close Overtime | Default: 3.0 range: 0.0~99.9 (Unit s) |
| | | c. DISC Gate Limit Signal Type | 0 when the signal is valid in place (when the input is valid, the door is considered to be in place). 1 the signal is invalid in place (when the input is invalid, the door is considered to be in place). |
| | | d. Discharge gate open frequency | Default: 30000 , range: 1~50000 (Unit Hz) |
| | | e. Discharge gate close frequency | Default: 20000 , range: 1~50000 (Unit Hz) |
| | | f. Discharge steps | Default: 12000 , range: 1~60000 |
| | | g. Motor Start Frequency | Default: 2000 , range: 1~50000 (Unit Hz) (this value can't bigger than discharge frequency) |
| | | h. ACC Time | Default: 200 , range: 0.0~9999 (Unit ms) |
| | | i. DEC Time | Default: 50 , range: 0.0~9999 (Unit ms) |
| | | j. IO function define | Optional A) Discharging direction signal status: 0 direction signal output is invalid when discharge door opening: when discharge mechanism opens the door, the direction signal output of discharge stepper motor is invalid, and the direction signal output is effective when closing the door; Direction signal output is effective when discharge and opening the door: when discharge mechanism opens the door, the rotation direction signal output of discharge stepper motor is effective, and the direction signal output is invalid when closing the door. B) Quickly define the discharge input port, discharge direction signal, discharge pulse output port switching quantity. |
| | k. Power on zero frequency | When the power is cut off and restarted, the clutch motor returns to the origin at this frequency. Initial value: 2000 , range: 0~50000 . (Unit Hz) | |
| | 2. Motor double limit discharge paracontrollers | a. discharge mode | Dual motor limit |
| | | b. DISC Gate Close Overtime | Default: 3.0 , range: 0.0~99.9 (Unit s) |
| | | c. DISC Gate | 0, when the signal is effective in place (when the |

| | | | |
|--|--|--|---|
| setting | Limit Signal Type | input is effective, the door is considered to be in place). 1, the signal is invalid in place (when the input is invalid, the door is considered to be in place). | |
| | d. DISC Gate Open Overtime | Default: 3.0 range: 0.0~99.9 (Unit s) | |
| | e. DISC Gate Open input | Quick setting of motor double limit discharge related switch input and output ports | |
| | f. DISC Gate Closed input | | |
| | g. DISC Gate Open Output | | |
| | h. DISC Gate Close Output | | |
| | i. Manual Discharge | Manual Discharge shortcut key | |
| | 3. Motor Drive Single-Limit paracontroller setting | a. Discharge Mode | MotorDrive Single-Limit |
| | | b. DISC Gate Close Overtime | Default: 3.0 , range: 0.0~99.9 (Unit s) |
| | | c. DISC Gate Limit Signal Type | 0, when the signal is effective in place (when the input is effective, the door is considered to be in place). 1, the signal is invalid in place (when the input is invalid, the door is considered to be in place). |
| d. DISC Gate Open Timer | | Motor opening signal output time Default: 1.00 , range: 0.00~99.99 (Unit s) | |
| e. Manual Discharge | | Manual Discharge short cut key | |
| f. DISC Gate Closed input | | Quick setting of motor single limit discharge related switch input and output ports | |
| g. DISC Gate Opened output | | | |
| h. DISC Gate Closed output | | | |
| 4. Motor Drive Rotating Discharge Paracontroller | a. Discharge Mode | MotorDrive Rotating | |
| | b. DISC Gate Close OT | Default: 3.0 , range: 0.0~99.9 (Unit s) | |
| | c. DISC Gate Limit Signal Type | 0, when the signal is effective in place (when the input is effective, the door is considered to be in place); | |

| | | |
|---------|----------------------------|---|
| setting | | 1, the signal is invalid in place (when the input is invalid, the door is considered to be in place). |
| | d. DISC Gate Open Timer | Motor Gate Open signal output timer Default: 1.00 , range: 0.00~99.99 (Unit s) |
| | e. Manual Discharge | Manual Discharge short cut key |
| | f. DISC Gate Open input | Quickly set the input and output ports of the I/O module related to discharging in one direction rotation of the motor. |
| | g. DISC Gate Closed input | |
| | h. DISC Gate Open output | |
| | i. DISC Gate Closed output | |

4.7 Statistics

In the main interface, click **【Statistics】** to enter the interface. Under the **【Statistics】** paracontroller, the user can view the total accumulation/batch, formula accumulation, user accumulation, history record and carry out clearing, printing and other operations.

- ◆ Under the **【Total ACCU/Batch】** interface, you can view the total accumulation and batch number and set the batch number. If the serial port is set to print, click **【Data Processing】** to print the total total and clear the total total and the batch.
- ◆ In total accumulated with batch interface can set **【Set Batch】**, such as a complete set of batch, controller in the main interface box prompts "batch complete alarm", wait for the user processing, when the "clear alarm" input signal effectively, or "clear alarm" button, controller will clear the alarm, it can remove or input stop back to stop state can clear alarm.
- ◆ Under "recipe ACUM", check the cumulative times and weight of each formula number. Click the right side of the interface to switch formula numbers 1-10 and 11-20. Click "Data Processing" to clear all formula accumulations, print all formula accumulations, print the current formula accumulations and select the formula to print.
- ◆ Click the formula accumulation to be deleted in the "recipe ACUM" interface to delete the selected formula accumulation content.
- ◆ Under **【User ACUM】**, check the cumulative times and weight of each user. Click **【Data Processing】** to clear all user accumulations, print all user accumulations, print current user accumulations, select user printing and other operations
- ◆ Click the user accumulation to be deleted in the **【User ACUM】** interface to delete the selected user accumulation content.
- ◆ In the **【History】** interface, you can view the history. Click **【Data Processing】** to export the history through the U disk or erase the historical data.

Note: if working in combination mode, the number of batches completed is increased by 1. The set number of batches and the accumulated number of batches are power-off and saved

4.8 I/O Module

The GM9907 provides 12 inputs and 16 output interfaces to interface the controller with external devices.

The input and output factory definition contents are as follows
 output 1 - 16 corresponds to the controller OUT1 ~ OUT16 interface,
 input 1 - 12 corresponds to the controller IN1 ~ 12 interface).

There are Net Weigher default definition:

| Output | | Input quantity | |
|-----------------|---------------------------|--|-----------------------------------|
| Output port -1 | O1 Running | Output port -1 | I1 Start |
| Output port -2 | O2 Stopped | Output port -2 | I2 Emergency Stop |
| Output port -3 | O3 Coarse Flow | Output port -3 | I3 Stop |
| Output port -4 | O4 Medium Flow | Output port -4 | I5 Zeroing |
| Output port -5 | O5 Fine Flow | Output port -5 | I6 Clear Alarm |
| Output port -6 | O6 Bag Lock | Output port -6 | I8 Clear Total ACUM |
| Output port -7 | O7 Result Waiting | Output port -7 | I7 Bag Lock/Unlock Request |
| Output port -8 | O8 Ready | Output port -8 | I9 Manual Discharge |
| Output port -9 | O9 Discharge | Output port -9 | I10 Manual Fine Flow |
| Output port -10 | O10 (-NZ-) | Output port -10 | I11 Manual Coarse Flow |
| Output port -11 | O11 Pag Bag | Output port -11 | I13 Change Recipe |
| Output port -12 | O13 FILL | Output port -12 | I12 Empty Material |
| Output port -13 | O14 EMPT | Note: In interlock mode. Input port -12 is the interlock input. Output port - 16 is the dual scale interlock output. | |
| Output port -14 | O15 Alarm | | |
| Output port -15 | O17 Batch Complete | | |
| Output port -16 | O16 Over/Under | | |

Gross Weigher scale default definition:

| Output | | Input quantity | |
|----------------|--------------------------|----------------|----------------------------------|
| Output port -1 | O1 Running | Input port - 1 | I1 Start |
| Output port -2 | O2 Stopped | Input port - 2 | I2 Emergency Stop |
| Output port -3 | O3 Coarse Flow | Input port - 3 | I3 Stop |
| Output port -4 | O4 Medium Flow | Input port - 4 | I4 Pause |
| Output port -5 | O5 Fine Flow | Input port - 5 | I5 Zeroing |
| Output port -6 | O6 Bag Lock | Input port - 6 | I6 Clear Alarm |
| Output port -7 | O7 Result Waiting | Input port - 7 | I7 BagLock/Unlock Request |

| | | | |
|-----------------|---------------------------|--|-------------------------------|
| Output port -8 | O10 (-NZ-) | Input port - 8 | I8 Clear Total ACUM |
| Output port -9 | O11 Pat Bag | Input port - 9 | I10 ,Manual Fine Flow |
| Output port -10 | O15 Alarm | Input port - 10 | I11 Manual Coarse Flow |
| Output port -11 | O13 FILL | Input port - 11 | I13 Change Recipe |
| Output port -12 | O27 Bag Release | Input port - 12 | I12 Empty Material |
| Output port -13 | O14 EMPT | Note: In interlock mode. Input port -12 is changed to interlock input . Output port -12 is changed to missing material. Output port- 13 is changed to batch completion. Output port- 14 is changed to the sewing machine output. Output port -15 is changed to conveyor output. Output port- 16 is changed to dual scale interlock output. | |
| Output port -14 | O17 Batch Complete | | |
| Output port -15 | O16 Over/Under | | |
| Output port -16 | O44 Sewing Output | | |

Jumbo Bags default definition:

| Output | | Input quantity | |
|-----------------|-----------------------------------|-----------------|----------------------------------|
| Output port -1 | O1 Running | Input port - 1 | I1 Start |
| Output port -2 | O2 Stopped | Input port - 2 | I2 Emergency Stop |
| Output port -3 | O3 Coarse Flow | Input port - 3 | I3 Stop |
| Output port -4 | O4 Medium Flow | Input port - 4 | I4 Pause |
| Output port -5 | O5 Fine Flow | Input port - 5 | I5 Zeroing |
| Output port -6 | O6 Bag Lock | Input port - 6 | I6 Clear Alarm |
| Output port -7 | O31 Hang bag | Input port - 7 | I8 Clear Total ACUM |
| Output port -8 | O34 Controlling bracket up | Input port - 8 | I7 BagLock/Unlock Request |
| Output port -9 | O7 Result Waiting | Input port - 9 | I32 Hanging Request |
| Output port -10 | O10 (-NZ-) | Input port - 10 | I3 Manual Hanger Up/Down |
| Output port -11 | O33 Return Valve | Input port - 11 | I19 Manual Fine Flow |
| Output port -12 | O32 AirBlow | Input port - 12 | I20 Manual Coarse Flow |
| Output port -13 | O15 Alarm | | |
| Output port -14 | O17 BatchComplete | | |
| Output port -15 | None | | |
| Output port -16 | None | | |

Valve scale default defined:

| Output | | Input quantity | |
|----------------|-----------------------|----------------|--------------------------|
| Output port -1 | O1 Running | Input port - 1 | I1 Start |
| Output port -2 | O2 Stop | Input port - 2 | I2 Emergency Stop |
| Output port -3 | O3 Coarse Flow | Input port - 3 | I3 Stop |
| Output port -4 | O4 Medium Flow | Input port - 4 | I4 Pause |
| Output port -5 | O5 Fine Flow | Input port - 5 | I5 Zeroing |
| Output port -6 | O6 Bag Lock | Input port - 6 | I6 Clear Alarm |

| | | | |
|-----------------|-------------------------------|-----------------|------------------------------------|
| Output port -7 | O07 Result Waiting | Input port - 7 | I18 Clear Total ACUM |
| Output port -8 | O17 Batch Completed | Input port - 8 | I17 Bag Lock/Unlock Request |
| Output port -9 | O10 (-NZ-) | Input port - 9 | I10 Manual Fine Flow |
| Output port -10 | O11 Pag Bag | Input port - 10 | I11 Manual Coarse Flow |
| Output port -11 | O13 FILL | Input port - 11 | I13 Change Recipe |
| Output port -12 | O15 Alarm | Input port - 12 | I12 None |
| Output port -13 | O16 Over/Under | | |
| Output port -14 | O30 Pushing Bag Signal | | |
| Output port -15 | O29 Lifting Bag Signal | | |
| Output port -16 | O42 Conveyor Start | | |

PLC mode default definition:

| Output | | Input quantity | |
|-----------------|------------------------------|-----------------|------------------------|
| Output port -1 | O03 Coarse Flow | Input port - 1 | I15 Zeroing |
| Output port -2 | O04 Medium Flow | Input port - 2 | I16 Clear Alarm |
| Output port -3 | O05 Fine Flow | Input port - 3 | None(No definition) |
| Output port -4 | O38 Over (PLC) | Input port - 4 | None |
| Output port -5 | O39 Under(PLC) | Input port - 5 | None |
| Output port -6 | O49 upper limite(PLC) | Input port - 6 | None |
| Output port -7 | O41 Lower limite(PLC) | Input port - 7 | None |
| Output port -8 | None | Input port - 8 | None |
| Output port -9 | None | Input port - 9 | None |
| Output port -10 | None | Input port - 10 | None |
| Output port -11 | None | Input port - 11 | None |
| Output port -12 | None | Input port - 12 | None |
| Output port -13 | None | | |
| Output port -14 | None | | |
| Output port -15 | None | | |
| Output port -16 | None | | |

4.8.1 Output, input port definition

Output port, input port content can be defined according to the actual application. Modify the definition of input and output I/O module paracontrollers through the menu interface I/O module paracontrollers. Each I/O module corresponds to a code, as follows:

I/O module content description

| Output | | |
|-----------|---------|--|
| Code | content | Description |
| O0 | None | If the port number is defined as 0 , this output port is undefined. |

| | | |
|------------|------------------|--|
| O1 | Running | When the controller is in the running state, the output port signal is valid. |
| O2 | Stopper | When the controller is in the stop state, the output port signal is valid. |
| O3 | Coarse Flow | Used to control the large discharge port of the filling mechanism. During the filling process, when the current weight is less than the target value -coarse advance amount, the output port signal is defined as valid. |
| O4 | Medium Flow | Used to control the middle discharge port of the filling mechanism. During the addition, the current weight is less than the target value - added inadvance during the definition output signal is active. |
| O5 | Fine Flow | Used to control the small discharge port of the filling mechanism. During the filling process, when the current weight is less than the target value -fall difference, the output port signal is defined as valid. |
| O6 | Bag Lock | It is used to control the pocket mechanism, and the signal effectively realizes the pocket; the signal is invalid, that is, the unlock bag. |
| O7 | Result Waiting | Used to indicate the end of the filling process. The output port signal is valid before the end of the fine addition to the discharge (with bucket) or the bag (no bucket). |
| O8 | Ready | After the setting is completed, the output port signal is valid. |
| O9 | Discharge | A discharge door for controlling the measuring bucket. The defined output port signal is valid when the discharge is started, so that the material is discharged from the measuring bucket into the package. |
| O10 | (-NZ-) | When the current weight of the scale is less than the set near zero value, the output port signal is valid. |
| O11 | Pat Bag | Used to control the bag making machine. A pulse signal with a controlled pulse width and number of times. |
| O12 | Cutting Material | This output is valid during the fill and is not valid during the non-fill period. |
| O13 | FILL | The filling mechanism for controlling the front end of the bagging scale, when the filling hopper lower level input (the lower material level input is defined) is invalid, the output is valid; when the filling hopper upper material level (the loading level input is defined) is valid, The controller invalidates this output. |
| O14 | EMPT | When the blanking input is defined and the input is invalid, the output is valid. When the hopper lowering level (the lowering input is defined) is valid, the controller invalidates the output. |
| O15 | Alarm | When the controller has an out-of-tolerance, batch number, etc. alarm, the output port signal is valid. |
| O16 | Over/Under | When the tolerance or undershoot is exceeded, the output |

| | | |
|-----|----------------------|---|
| | | signal is defined as valid. |
| O17 | Batch complete | When the set number of batches is completed, the output port signal is valid. |
| O18 | Interlock Output | Used in the double scale mode, connected to the ON/OFF “Double scale interlock input” of another controller. |
| O19 | Filling O/P PU | When the filling mode is set to stepper motor mode to control the filling door ON/OFF: This signal is used as a pulse signal output to the filling stepper motor driver to control the motor rotation. Note: This function can only be defined on one of the ports of OUT12~16 . |
| O20 | Filling O/P DR | When the filling mode is set to stepper motor mode to control the filling door ON/OFF: This signal is used as the motor rotation direction signal output to the filling stepping motor driver to control the motor to reverse. Note: This function can only be defined on one output port. There can be no multiple output ports to define this function. And can only be defined to one of the ports OUT1~11 . |
| O21 | Bag Clutch O/P PU | When the bag mode is set to the stepping motor mode control lock unlock bag: This signal is used as the output pulse signal to the pinch stepper motor driver to control the motor rotation. Note: This function can only be defined on one of the ports of OUT12~16 . |
| O22 | Bag Discharge O/P DR | When the bag mode is set to the stepping motor mode control lock unlock bag: This signal is used as the motor rotation direction signal output to the pinch bag stepping motor driver to control the motor to reverse. (No bucket mode is valid) Note: This function can only be defined on one output port. There can be no multiple output ports to define this function. And can only be defined to one of the ports OUT1~11 . |
| O23 | DISC O/P PU | When the unloading mode is set to stepper motor mode to control unloading: this signal is used as a pulse signal output to the discharge stepper motor driver to control the motor rotation. Note: This function can only be defined on one of the ports of OUT12~16 . |
| O24 | DISC O/P DR | When the unloading mode is set to stepper motor mode to control unloading: this signal is used as the motor rotation direction signal output to the discharge stepper motor driver to control the motor to reverse. Note: This function can only be defined on one output port. There can be no multiple output ports to define this function. And can only be defined to one of the ports OUT1~11 . |

| | | |
|------------|--|--|
| O25 | Filler Open | When the filling mode is set to the normal motor mode to control the filling door ON/OFF: the large discharging port for controlling the weighing mechanism is opened. This signal is active at the beginning of the filling process and the effective time is set in the motor paracontrollers. |
| O26 | Filler Close | When the filling mode is set to the normal motor mode to control the filling door ON/OFF: it is used to control the action of closing the filling port of the filling mechanism. The signals are valid at the time of coarse addition, medium addition and fine addition respectively. The effective time is based on the time paracontroller set in the motor paracontrollers. It is decided that the signal is valid at the end of the fill until it becomes invalid when the fill limit is valid. |
| O27 | Bag Release | When the bag mode is set to the ordinary motor control lock unlock bag: it is used to control the unlock bag. When the signal is valid, the motor is driven to perform the unlock bag action. When the signal is invalid, the unlock bag action stops. |
| O28 | DISC Gate Close | When the unloading mode is set to normal motor forward and reverse control discharge, it is used to control the closing action of the controlling bucket discharge door. When the signal is valid, the motor is driven to open and close the door. When the signal is invalid, the door closing action stops. |
| O29 | Lifting Bag Signal | It is used to control the bag-making mechanism, and this signal effectively realizes the bag-lifting action . |
| O30 | Pushing Bag Signal | It is used to control the push bag mechanism, and the signal effectively realizes the push bag action. |
| O31 | Hanging Bag | It is used to control the bag mechanism, and the signal effectively realizes the hanging bag; the signal is invalid and the hook is unlock. |
| O32 | AirBlow | For controlling the operation of the blowing means,at the end of the controlling bracket upward, the signal is valid. |
| O33 | Return Valve | Return valve for controlling the run, at the end of blowing, the signal is valid. |
| O34 | Hanger Up (this paracontroller is reserved) | Used to control the upstream of the controlling bracket. This signal is valid until the upper limit is valid if both the bag and the bag have been completed before filling. This signal output is valid after the unlock bag is completed. Until the lower limit input is valid. |
| O35 | Hanger Down (motor)(this paracontroller is reserved) | Used to control the downstream of the controlling bracket . (When there is a bag making function, it needs to be started after the bag is finished) . |
| O36 | Convery A (this paracontroller is reserved) | Electric mode, for controlling the operation of the belt A, the unlock bags, the hook after the song, the signal is valid. |

| | | |
|------------|--|--|
| O37 | Convery B (this paracontroller is reserved) | Electric mode, for controlling operation of the belt B , the belt A is stopped, the signal is valid. |
| O38 | Over(PLC) | This signal is valid when it is out of tolerance (PLC) . |
| O39 | Under(PLC) | This signal is valid when there is a short circuit (PLC) . |
| O40 | Upper Limite (PLC) | When the weighing value > upper limit value, the upper limit output is valid . |
| O41 | Lower Limite (PLC) | When the weighing value < lower limit, the lower limit output is valid . |
| O42 | Conveyor Start | In the bucketless mode, it is used to control the start and stop of the conveyor. The signal is effectively activated by the conveyor and the signal is invalid and the conveyor is stopped. |
| O43 | Coding | The code signal is output when the pocket signal output is valid and the code delay is over. |
| O44 | Sewing Output | When the sewing machine input is valid, the sewing machine output is valid. |
| O45 | Cutter Output | After the sewing machine output time is over, the output is valid, and the effective time is the tangential machine output time . |
| O46 | Auxiliary Output 1 PU | After the auxiliary pulse input effective, the output pulse signal (valid for the auxiliary pulse aneffective time, dead time of the auxiliary pulse adead time), and outputs the total time to stop the output (the total time is set to 0 , it has been by Pulse output) . |
| O47 | Auxiliary Output 2 PU | After the auxiliary pulse 2 input is active, the output pulse signal (valid for the auxiliary pulse 2effective time, dead time of the auxiliary pulse 2dead time), and outputs the total time to stop the output (the total time is set to 0 , it has been by Pulse output) . |
| O48 | Auxiliary Output 3 PU | After the auxiliary pulse 3 input is valid, the pulse signal is output (the effective time is theauxiliary pulse 3 valid time, the invalid time is the auxiliary pulse 3 invalid time), and after the output execution total time is reached, the output is stopped (the total execution time is set to 0 , then the button is pressed. Pulse output) . |
| O49 | Auxiliary Output 4 PU | After the auxiliary pulse 4 input is valid, the pulse signal is output (the effective time is theauxiliary pulse 4 valid time, the invalid time is the auxiliary pulse 4 invalid time), and after the output execution total time is reached, the output is stopped (the total execution time is set to 0 , then the button is pressed. Pulse output) . |
| O50 | DISC Patting Output | The output of the discharge rapping function. |
| O51 | User Logic Output 1 | Auxiliary logic 1 output signal. |

| | | |
|-----------------------|--|--|
| O52 | User Logic Output 2 | Auxiliary logic output signal 2. |
| O53 | User Logic Output 3 | The output signal of the auxiliary logic output 3 . |
| O54 | User Logic Output 4 | The output signal of the auxiliary logic output 4 . |
| O55 | User Logic Output 5 | The output signal of the auxiliary logic output 5 . |
| O56 | User Logic Output 6 | The output signal of the auxiliary logic output 6 . |
| O57 | Multi-function support control patting bag (ton bag scale mode) | For one - piece control bracket and patting bag. When the patting bag is not executed: this I/O Module is the same as the uplink state of the measuring bracket. When the function of patting bag is on: this I/O Module is opposite to the state of patting bag.(valid patting bag support is invalid, invalid patting bag support is valid). |
| O58 | Conveyor 2 output | Control conveyor 2 output is valid |
| O59 | Conveyor 3 output | Control conveyor 3 output is valid |
| O60 | Conveyor 1 reverse output | Control conveyor 1 reverse output is valid |
| Input quantity | | |
| I0 | None | If the port number is defined as 0 , this input port is undefined. |
| I1 | Start | The signal valid controller will enter the running state.This input is a pulse input signal. |
| I2 | Emergency Stop | The signal valid controller will return to the stop state. This input is a pulse input signal. |
| I3 | Stop | The signal valid controller will return to the stop state after completing the current bagging process. This input is a pulse input signal. |
| I4 | Pause | The signal valid controller will suspend work, retain the current state, and resume working after receiving the start signal. This input is a pulse input signal. |
| I5 | Zeroing | The signal valid controller will clear the weight. This input is a pulse input signal. |
| I6 | Clear Alarm | Used to clear the alarm output of the controller. This input is a pulse input signal. |
| I7 | Bag Lock/Unlock | It is used to control the action of the pocket mechanism. This input is effective for one pocket output, and the effective pocket output is invalid again (ie: unlock bag). |
| I8 | Clear Total ACUM | Clearing the total accumulated weight and number of times will also clear the recipe accumulation and user accumulation . |

| | | |
|------------|----------------------------------|--|
| I9 | Manual Discharge | Used to manually remove material from the measuring hopper. The input is effective once, the discharge output is valid, and the effective discharge output is invalid again. |
| I10 | Manual Fine Flow | The input is valid once and the output is valid, and the effective fine input is invalid again. |
| I11 | Manual Coarse Flow | Pulse type signal. Function in the stop state, used to manually turn the controller on and off. Effective once, it is effectively turned off again. |
| I12 | Empty Material | Pulse type signal. Acting in the stop state, used to empty the storage hopper while opening the discharge door and the fill door. Effective once, it is effectively turned off again. (Gross Weigher, PLC, valve port, Jumbo Bag) |
| I13 | Change Recipe | This input is valid once, the recipe number is changed to the next target whose value is not zero, and the recipe number with the target value of zero is skipped. |
| I14 | Supplement Full | Used to connect the upper level of the hopper, this input should be level input. |
| I15 | Supplement Empty | Used to connect the lower level of the hopper, this input should be level input. The blanking bit input is invalid or left blank to indicate the material shortage. The blanking level input is valid to indicate that there is no shortage of material. |
| I16 | Start/E-stop (level Signal) | The signal is valid and the controller enters the running state. If it is invalid, it returns to the stop state. This input is a level signal. |
| I17 | Start/Stop (level Signal) | The signal valid controller enters the running state, and if it is invalid, it returns to the stop state after completing the current bagging process. This input is a level signal. |
| I18 | M Discharge (level Signal) | Used to manually remove material from the measuring hopper. The input effective discharge output is valid, and the input invalid discharge output is invalid. |
| I19 | M Fine Flow (level Signal) | The signal is effectively fine and the signal output is valid. The signal is invalid and the fine signal output is invalid. |
| I20 | M Coarse Flow(level Signal) | The signal is valid and the signal output is valid. The signal is invalid and the signal output is invalid. |
| I21 | Bag Locked (level Signal) | If this input is defined, it effectively indicates that the pocket is in place, and vice versa . No fighting mode: the folder bag has state, the controller must be detected "bag-in place" input active material began to increase, the process of adding material, detecting whether the signal is not valid. This input should be a level input. |
| I22 | DISC Gate Opened (level Signal) | The unloading mode is set to the normal motor forward and reverse double limit mode to control the unloading: this signal is used as the limit input signal of the discharge door opening door. When the controller detects that the signal is valid, it considers that the discharge door has been opened. |

| | | |
|------------|---|---|
| I23 | Filler Gate Closed (level Signal) | When the unloading mode is set to normal motor forward and reverse double limit mode to control unloading: this signal is used as the limit input signal of the filling door closing door. When the controller detects that the signal is valid, it considers that the filling door has been closed. |
| I24 | DISC Gate Closed (level Signal) | This signal acts as a limit input signal for the discharge door to close the door. When the controller detects that the signal is valid, it considers that the discharge door has been closed. |
| I25 | Bag Released (level Signal) | The pocket mode is set to stepper motor lock unlock bag / motor double limit lock unlock bag mode control lock unlock bag: This signal is used as the limit input signal of the pocket bag unlock bag in place. (Note: This signal is determined by the type of in-position signal and is set to positive logic: when the input signal is valid, it is considered that the pocket mechanism has been unlocked in place ; set to reverse logic: when the input signal is invalid, it is considered that the pocket mechanism has been unlocked in place.) |
| I26 | Sewing Input | When the digital input is valid, the effective output of the sewing machine is started. |
| I27 | Sewing Emergency | When the digital input is valid, the sewing machine stops outputting. |
| I28 | Auxiliary PU Input 1 | Auxiliary PU Input 1 self defined trigger input signal |
| I29 | Auxiliary PU Input 2 | Auxiliary PU Input 2 self defined trigger input signal |
| I30 | Auxiliary PU Input 3 | Auxiliary PU Input 3 self defined trigger input signal |
| I31 | Auxiliary PU Input 4 | Auxiliary PU Input 4 self defined trigger input signal |
| I32 | Hanger Request | Used to control the movement of the bag mechanism. |
| I33 | Hanger Up Done | The upper limiter for connecting the controlling bracket, this input should be a pulse input . |
| I34 | Hanger Down Done | The lower limiter used to connect the controlling bracket, which should be a pulse input . |
| I35 | Hanger Lower Limitation | The lower limiter for connecting the controlling bracket, this input should be a pulse input . |
| I36 | Convery A Stop (this paracontroller is reserved) | In the electric mode , the stop detection load cell for connecting the belt A , which should be a pulse input . |
| I37 | Convery A Stop (this paracontroller is reserved) | In the electric mode, the stop detection load cell for connecting the belt B should be a pulse input. |
| I38 | Manual Hanger | Used to control the motion of the stand, this input is a pulse |

| | | |
|-----|--|--|
| | Up/Down(this paracontroller is reserved) | input. The motion of the stand can be controlled in the stopped state. In the running state, it is the start signal of the motion of the bracket. |
| I39 | Interlock Input | Used in the double scale mode, the ON/OFF "double scale interlock output" used to connect another controller. |
| I40 | Auxiliary logic input 1 | Auxiliary PU Input 1 self defined trigger input signal. |
| I41 | Auxiliary logic input 2 | Auxiliary PU Input 2 self defined trigger input signal. |
| I42 | Auxiliary logic input 3 | Auxiliary PU Input 3 self defined trigger input signal. |
| I43 | Auxiliary logic input 4 | Auxiliary PU Input 4 self defined trigger input signal. |
| I44 | Auxiliary logic input 5 | Auxiliary PU Input 5 self defined trigger input signal. |
| I45 | Auxiliary logic input 6 | Auxiliary PU Input 6 self defined trigger input signal. |
| I46 | Filling allow input | If the Filling allow input is defined in the I/O Module, judge whether the Filling allow input is valid before the filling process. If it is valid, start the filling process; if not, wait. |
| I47 | Discharge allow input | Discharge allow input is only for Net Weigher. If discharge allow input is defined in the I/O Module, it is necessary to judge whether the discharge allow input is valid after setting the value. If it is valid, the discharge process will start; if it is not, it will wait. |
| I48 | Conveyor 1 is turning forward | At stop status, manual control conveyor starts turning forward(When the emergency stop signal is valid, the forward turning output of conveyor 1 is invalid) |
| I49 | Conveyor 1 is turning reversal | Control conveyor starts reversal (When the emergency stop signal is valid, the reversal turning output of conveyor 1 is invalid) |
| I50 | Conveyor limit input 2 | Conveyor 2 Limit Signal Type |
| I51 | Conveyor limit input 3 | Conveyor 3 Limit Signal Type |

4.9 Host mode

Host mode to communicate with the slave to send commands, using host mode, note the following points.

- ◆ The communication paracontrollers of serial port 2 are fixed in host mode. Only when the communication mode is Modbus-RTU mode can host mode be used, otherwise it is prohibited.
- ◆ In host mode, the starting address is fixed to 1

- ◆ Successful write will return successful send; Failure to write data returns failure to send; when there is no return for a long time, the return send timeout.
- ◆ In host mode, changing the high and low bytes of serial port 2 will change the storage order of data sent to the slave. The high and low bits correspond to each other, and the data can be used when the length is double word

| | | |
|-----------|-------------------------|---|
| Host mode | 1. Communication ID | Initial value: 1 ; 1~99 option |
| | 2. Data Length | Initial value: single byte; single byte /double byte option |
| | 3. Initial value | Initial value: 1 ; 1~65535 option, default initial address starts from 0X0001 |
| | 4. Write paracontroller | Initial value: 0 ; 0~999999 option |

5. Function

5.1 Setting the working mode

The GM9907- L2 has **five** scale body structures. Choose between the system and the communication - scale structure.

They are: Net Weigher, Gross Weigher, **PLC mode**, Jumbo Bags, valve scales .

(Note: Among them, the working mode of the Net Weigher and Gross Weigher supports the dual scale interlock mode. Other scales do not support the dual scale interlock mode)

5.2 Batches

The batch number is used for reminder of the number of packages. When the set number of batches is completed during the automatic running process, the controller issues the batch number to the alarm and stops, waiting for the user to process, the batch number and the alarm output are valid. At this time, press the clear alarm button or make The “clear alarm” input signal is valid and the controller will clear the above alarm. If the batch number is set to **0** , the batch number judgment is not performed.

The batch number ranges from **0 to 50000**. The initial default value is **0** (no batch count judgment).

5.3 Level control

Due to the different application conditions, the filling device of the storage scale storage bin is divided into **two** types: double material level (upper and lower material level), single material level (lower material level) and no level positioner.

5.3.1 Double digit

The upper and lower material levels are defined, corresponding to the double material level. At this time, the controller has a filling control function, and the control principle is: when the upper and lower material level inputs are invalid, the controller filling output is valid; when the filling level input is valid, the filling output is invalid. At the same time, before each filling (coarse , medium, fine), the controller will check whether the lower level is valid. If it is invalid, wait for this signal; only when this signal is valid, the filling process starts. During the filling process, the controller does not detect whether the material level signal is valid.

5.3.2 Single Level

The blanking level is defined, and the loading level is not defined, corresponding to the single material level. At this point the controller will not perform fill control. Only the fill level is detected before filling. If the material level is invalid, wait for this signal; only when

this signal is valid, the filling process starts. During the filling process, the controller does not detect whether the material level signal is valid.

The upper and lower material levels are not defined, corresponding to the situation without the positioner. At this time, the controller does not perform the filling control, and the raw material level is not detected before the filling.

5.4 Quick setup

In the stopped state, the quickly modified recipe data is saved in real time.

The data modified during operation, the zero zone value is saved in real time, and other recipe paracontrollers are automatically updated when the next scale is started after exiting the quick setting interface (the combination mode is to be released after the unlock bag is started and the next scale target value is updated).

The recipe paracontrollers are modified during operation, but when the next scale is updated, the emergency stop signal is entered and the controller is stopped and the recipe is updated immediately.

M odbus can also be carried out at runtime when communicating recipe quantitative value changes, but can not modify the recipe number.

5.5 Adaptive function

The adaptive function is a convenient function to adjust the filling speed when the user first uses the controller. When this function is turned on, it will automatically adjust the paracontrollers such as the coarse increase advance amount, the medium increase advance amount, the fine increase advance amount, the coarse add ban time, the medium plus ban time, and the fine add time. The filling process is optimized.

Note:

1. All advances must be zero in order to be used normally.
2. If the drop correction and the adaptive function are turned on at the same time, the drop correction function is forcibly turned off.
3. When the first scale is adaptively started, the scale body must be stable and the current weight is zero.

5.6 U disk upgrade software

5.6.1 Upgrade process

Proceed as follows:

| | |
|----|--|
| 1. | containing the upgrade kit "TPCBACKUP" into the controller |
| 2. | Power up the controller, and the message "You are using the comprehensive function package of MCGSTPC USB flash disk, click 'Yes' to enter the system setting interface and start the comprehensive function package, click' No 'to exit" pops up;Click "Yes" and the "User Project Update" button pops up |
| 3. | Click "user project update" button, select GM9907 - L2 engineering began to download |
| 4. | Download success, restart automatically |

5.6.2 U disk upgrade boot interface

Proceed as follows:

| | |
|----|---|
| 1. | Insert the USB flash drive into the computer and create a new " GM9907-L2 " folder in the USB flash drive |
| 2. | Save the image of “ GM9907-L - Logo .bmp ” into the “ GM9907-L2 ” folder; |
| 3. | Plug the USB flash disk into the controller, switch to the system Engineer permissions, go to the System Maintenance - Software Upgrade interface, long press the blank in the lower right corner of 5S, and the "Click Upgrade" button pops up, jump to the upgrade interface, click "Upgrade", click "Upgrade" again, and the words "Upgrade in process" appear, indicating that the controller is upgrading the background |
| 4. | When the progress bar is finished, the upgrade will be successful after the countdown of 10s and the login interface will be switched to |

5.7 U disk upgrade boot interface

Proceed as follows:

| | |
|----|--|
| 1. | Save the image file (resolution 800*480, format.bmp) into the root directory of U disk containing the project package (tpcbakup) |
|----|--|

| | |
|----|---|
| 2. | Insert the USB flash drive into the controller |
| 3. | The controller pops up the display box of [Equipment vendor USB disk kit], and select "Update startup bitmap". |
| 4. | Enter the LOGO selection interface, select the image to be upgraded, and click OK. It will prompt you to restart after successful bitmap update |

5.8 Decoupling function

Decoupling formula paracontrollers of ton bag scale paracontrollers, the decoupling upstream ON/OFF is opened:

Setting value after filling, unlock bag, control equipment bracket downward, downward after, take off the hook, the conveyor start, after decoupling before delay on bracket start up, decoupling upward duration, then execute the uplink pause time, pause time arrives, stent decline, time duration for decoupling.

Decoupling alarm:

If the uncoupled alarm ON/OFF is opened, during this process, if the current weight value is greater than the uncoupled alarm weight value, the machine will stop and the uncoupled alarm will be stopped. The conveyor performs reversal.

Note: This function is mainly used for prevention. After the filling, the bag can't take off the hook completely. When the conveyor is running, the current weight value will suddenly increase, resulting in controller damage

5.9 Running mode of bracket

Running mode of bracket: Air Drive-unlimit、Motor Drive-dual limit、Air Drive-dual limit

Air Drive-unlimit

I/O Module: bracket uplink

When the controlling bracket is mounted, the uplink output of the controlling bracket is effective. After the uplink delay time of the controlling bracket, the uplink of the controlling bracket is in place. (During operation, after ascending to position, the controller can start peeling and filling, etc.)

When the measuring support goes down, the uplink output of the measuring support is invalid. After the delay time of the measuring support goes down, the support goes down in place. (In operation, the controller can start to take off the hook after the downlink is in place)

Motor Drive-dual limit:

I/O Module input: support up in place, support down in place. I/O Module output: controlling support up, controlling support down.

When the measuring support is mounted, the uplink output of the measuring support is effective, while the downlink output of the measuring support is invalid. Wait for the uplink of the measuring support to be in place. If the support is still not in place within the uplink timeout period, the rising timeout alarm will be given. After the up-flow is in place, the up-flow output of the controlling support and the down-flow output of the controlling support are invalid

When the controlling support is in the downward direction, the downstream output of the controlling support is effective, while the upstream output of the controlling support is invalid. If the support is still not in the downward direction within the downward timeout period of the support, the downward timeout alarm will be given. When the downlink is in place, the downlink output of the controlling support and the uplink output of the controlling support are both invalid

Air Drive-dual limit:

I/O Module input: support up in place, support down in place. I/O Module output: controlling support up, controlling support down.

When the measuring support is mounted, the uplink output of the measuring support is effective, while the downlink output of the measuring support is invalid. Wait for the uplink of the measuring support to be in place. If the support is still not in place within the uplink timeout period, the rising timeout alarm will be given. After the up-flow is in place, the up-flow output of the controlling support is effective, while the down-flow output of the controlling support is invalid

When the controlling support is in the downward direction, the downstream output of the controlling support is effective, while the upstream output of the controlling support is invalid. If the support is still not in the downward direction within the downward timeout period of the support, the downward timeout alarm will be given. When the downlink is in place, the downlink output of the controlling support is effective, while the up-link output of the controlling support is invalid

5.10 Use method of 3 - class conveyor for ton baling scale

Three conveyors are placed under the ton-bale balance. Conveyor No. 1 is placed under the ton-bale balance. One bag of materials is placed on conveyor 1 after decoupling. Conveyor 2 is behind conveyor 1. Conveyor 3 is behind conveyor 2. There is a limit switch (approach switch) at the end of conveyor 2 and 3 respectively.

1) If the limit switch (approach switch) of conveyor 3 is invalid, then conveyor 2 and Conveyor 3 will rotate to transport materials to conveyor 3. When the limit switch (approach switch) of conveyor 3 is effective, the rotation of conveyor 3 will stop. Similarly, conveyor 1 transports materials to conveyor 2.

2) When the upper limit switch (proximity switch) of conveyor 2 is in effect, conveyor 1 cannot start operation even though it has been disconnected. When the limit switch (proximity switch) of conveyor 2 is invalid, conveyor 1 rotates to transport materials to conveyor 2.

3) When there are materials in conveyor 3 and Conveyor 2, the forklift truck can shovel the materials away and wait for the next start and rotation.

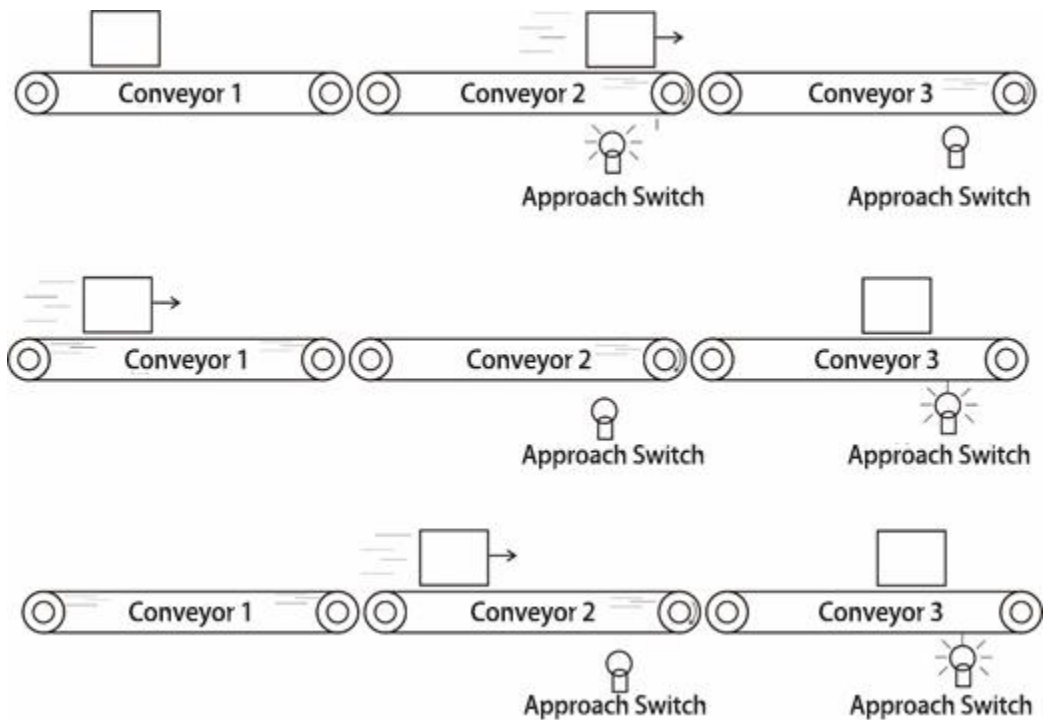

6. Serial communication

GM9907 provides two serial communication interface, and serial port 1 and 2 can be selected in a continuous manner, **Modbus** mode and printed three kinds of functions. The first serial port of the controller is **RS - 232** and the second serial port of the controller is **RS - 485**.

6.1 Printing method

When the serial port serial port **1** or serial port **2** is selected as the **printing** mode, the corresponding serial port can realize the printing of the related accumulated content by connecting the serial printer.

The communication paracontrollers related to the printing method refer to the serial port paracontroller items, among which are noted:

- 1) **Baud Rate** - This paracontroller should be selected in accordance with the printer settings used for the connection.
- 2) **Communication Format** - This paracontroller should be selected in accordance with the printer settings used for the connection.

Note: When the print language is selected as Chinese, the data bit cannot be used in 7-bit format, otherwise there will be an error in printing.

- 3) **Print Format** - The peripheral **format** allows you to set the print format to **24** columns or **32** columns. In addition, the print language of the peripheral paracontrollers is set to Chinese or English.

6.1.1 Auto print

In the **print** mode, the automatic print ON/OFF for peripheral paracontrollers is set to **On**. Then, each time the weighing of the controller is completed, the weighing result will be printed automatically. The format is as follows:

| The English 24 column print format is as follows: | The English 32 column print format is as follows: |
|---|---|
| Packing Detail | Packing schedule |
| Unit : kg | Unit: kg |
| Recipe ID : 20 | Recipe number: 20 |
| Total ACUM PCS Result | Total ACUM PCS Target Result |
| ----- | ----- |
| 1 5.50 | 3 5.60 5.50 |
| 2 5.50 | 4 6.00 5.80 |

6.1.2 Total cumulative printing

In the **printing** mode, stop the state, enter the “Accumulate and Batch” interface, and click “Print Total Accumulation”. The format is as follows:

| | |
|--|--|
| <p>The English 24 column print format is as follows:</p> <p>Total ACUM report Time: 2018/6/19 13:28 Unit: kg</p> <p>-----</p> <p>PCS: 18 Wt: 84.16</p> <p>-----</p> | <p>The English 32 column print format is as follows:</p> <p>Total ACUM report Time: 2018/6/19 13:36 Unit: kg</p> <p>-----</p> <p>PCS: 24 Wt: 129.40</p> <p>-----</p> |
|--|--|

6.1.3 Formula cumulative printing

In the printing mode, stop the state and enter the “Accumulate and Batch” interface. Select “Recipe Accumulation” and click “Print Selected Receipts” .

Click the "Print all the recipes rolled-up" to print all the recipes (**1 to 20**) accumulated, the controller will automatically skip the cumulative recipe **0** does not print. The format is as follows:

| | |
|---|---|
| <p>The English 24 column print format is as follows:</p> <p>All Recipe ACUM Report Time: 2018/6/19 13:29 Unit: kg</p> <p>-----</p> <p>Recipe ID: 20 PCS: 18 Wt: 84.16</p> <p>-----</p> | <p>The English 32 column print format is as follows:</p> <p>All Recipe ACUM Report Time: 2018/6/19 13:36 Unit: kg</p> <p>-----</p> <p>Recipe ID: 20 PCS: 24 Wt: 129.40</p> <p>-----</p> |
|---|---|

6.1.4 User cumulative printing

In the printing mode, stop the state and enter the “Accumulate and Batch” interface. ON/OFF to the user cumulative interface and press "Print Selected User Accumulation".

Click “Print All Users Accumulate” to print the total of all users (0~9). The controller will automatically skip users whose user accumulation is 0 and will not print. The format is as follows:

| | |
|---|---|
| <p>The English 24 column print format is as follows:</p> | <p>The English 32 column print format is as follows:</p> |
|---|---|

53 54 2C 47 53 2C 2B 30 31 31 2E 31 32 30 6B 67 0D 0A

The current state is stable, the data value is positive, and the display value is 11.120kg

6.4 Modbus-RTU Protocol

The communication mode selected in serial port 1 or serial port 2 is Modbus-RTU mode.

6.4.1 Abnormal function code and code

◆ Function code supported by the controller:

| function code | name | Description |
|---------------|--------------------------|--|
| 03 | Read register | Read up to 125 registers in a single pass . |
| 06 | Write a single register | Use this function code to write a single holding register. |
| 10 | Write multiple registers | This controller only supports writing double registers. It must be aligned when writing. It is not allowed to write only a part of dual registers. Read-only part is allowed when reading. |
| 01 | Reading coil | Note that this length is in bits . |
| 05 | Write coil | |

Note: This controller only supports the above MODBUS function code. When the controller performs other function codes, the controller will not respond.

◆ MODBUS exception code response

| Code | name | meaning |
|------|----------------------------------|--|
| 02 | Illegal data address | For the controller, the error code indicates that the data address received is an address that is not allowed. |
| 03 | Illegal data value | The portion of data written and the allowed range. |
| 04 | Slave failure | An unrecoverable error occurs when the controller is attempting to perform the requested operation. |
| 07 | Unsuccessful programming request | For the controller, the received command cannot be executed under the current conditions. |

6.4.2 MODBUS transmission mode

The **MODBUS** transmission mode is the **RTU** mode.

When communication with the **RTU** mode, information of each **8-bit** byte is divided into **two 4-bit** transmission character **hexadecimal**.

Data format: **8** -bit data bit, **1** stop bit, even parity (**8-E-1**)

8 -bit data bit, **1** stop bit, no parity (**8-N-1**)

Baud rate: **9600/19200/38400/57600/115200** (optional)

Code: **RTU**

Example :

Read command:

| Command function (single /double) byte | COM ID. | function code | Data address | Number of data read | CRC check code | |
|--|------------|------------------|-----------------|------------------------|----------------|----|
| | | | | | | |
| Read weight (double) | 01 | 03 | 0002 | 0002 | 65 | CB |
| Target value (double) | 01 | 03 | 01F6 | 0002 | 25 | C5 |
| Zero voltage (double) | 01 | 03 | 0069 | 0002 | 14 | 17 |
| Gain voltage (double) | 01 | 03 | 006B | 0002 | B5 | D7 |

Write command:

(Note: Write weight data with 50 as an example. When it is displayed as two decimal places, it should be written to 5000)

| Command function (single /double) byte | CO M ID. | func tion code | Data address | Write register number | Write bytes | data input | CRCcheck code | |
|--|----------------|----------------------|-----------------|-----------------------------|----------------|---------------|------------------|----|
| | | | | | | | | |
| Write target value (double) | 01 | 10 | 01F6 | 0002 | 04 | 0000 1388 | 7C | 07 |
| Zero calibration (double) | 01 | 10 | 0069 | 0002 | 04 | 0000 0001 | F4 | 2D |
| Gain calibration (double) | 01 | 10 | 006B | 0002 | 04 | 0000 1388 | B9 | 62 |

5.3.3 MODBUS address allocation

| Protocol address | PLC address | meaning | Description | |
|---------------------|-----------------|--------------------------|--|--|
| 0000-0001 | 40001-40002 | GW | Controller display GW value, signed | |
| 0002-0003 | 40003-40004 | NW | Controller display NW value, unsigned | |
| 0004-0005 | 40005-40006 | GW | GW Value | |
| 0006-0007 | 40007-40008 | Control status (bit) | Bit | Description |
| | | | . 0 | Unstable weight : 0; stable : 1 |
| | | | . 1 | Non-zero : 0 ; zero :1 |
| | | | . 2 | Currently showing the weight of the symbol +/- Positive sign : 0 ; minus sign : 1 |
| | | | . 3 | overflow |
| . 4 | Weight overflow | | | |

| | | | | |
|-----------|-------------|------------------|-----------|--|
| | | | . 5 | Negative weight overflow |
| | | | . 6 | Load cell is overflowing |
| | | | . 7 | Load cell negative overflow |
| | | | . 8 | Millivolts stable:1 unstable: 0 |
| | | | . 9~ . 31 | Reserved |
| 0008-0009 | 40009-40010 | Operating status | .0 | 0 : stop; 1 : run |
| | | | .1 | Before filling |
| | | | .2 | Coarse Flow |
| | | | .3 | Medium Flow |
| | | | .4 | Fine Flow |
| | | | .5 | Result Checking |
| | | | .6 | Ready |
| | | | .7 | Discharge |
| | | | .8 | (-NZ-) |
| | | | .9 | Over |
| | | | .10 | Under |
| | | | .11 | Qualified(合格) |
| | | | .12 | OVER/UNDER Pause |
| | | | .13 | Bag Lock |
| | | | .14 | Lifting Bag (valve) |
| | | | .15 | Pushing bag (valve) |
| | | | .16 | Hanging bag (ton pack) |
| | | | .17 | AirBlowing (ton pack) |
| | | | .18 | Return Valve (ton pack) |
| | | | .19 | Hanger Up (ton pack) |
| | | | .20 | Hanger Down (ton pack) |
| | | | .21 | Upper limite (PLCmode) |
| | | | .22 | Lower limite (PLCmode) |
| | | | .23 | Batch complete |
| | | | .24 | Alarm |
| | | | .25 | Gross weight status: 1 : Net :0 : Gross |
| | | | .26 | Clear |
| | | | .27 | OverLimit (PLC) |
| | | | .28 | UnderLimit (PLC) |
| | | | .29 | In the non-bucket mode, after unlock the bag, the mark is valid until the end of this filling |
| | | | .30 | Stop |
| .31 | Pause | | | |
| 0010-0011 | 40011-40012 | Control state 2 | .0 | Dual scale Interlock Output (interlock mode) |
| | | | .1 | Supplement Full |

| | | | | |
|------------------|--------------------|-----------------------|-----|--|
| | | | .2 | Supplement Empty |
| | | | .3 | FILL |
| | | | .4 | EMPT |
| | | | .5 | Cutting Material |
| | | | .6 | Pat Bag |
| | | | .7 | Coding |
| | | | .8 | DISC Patting Output |
| | | | .9 | Conveyor Start |
| | | | .10 | Sewing output |
| | | | .11 | Cutter Output |
| | | | .12 | Auxiliary PU Output 1 |
| | | | .13 | Auxiliary PU Output 2 |
| | | | .14 | Auxiliary PU Output 3 |
| | | | .15 | Auxiliary PU Output 4 |
| | | | .16 | User Logic Output 1 |
| | | | .17 | User Logic Output 2 |
| | | | .18 | User Logic Output 3 |
| | | | .19 | User Logic Output 4 |
| | | | .20 | User Logic Output 5 |
| | | | .21 | User Logic Output 6 |
| | | | .22 | Convery A (ton pack) |
| | | | .23 | Convery B (ton pack) |
| | | | .24 | Manual Fine Flow |
| | | | .25 | Manual Discharge |
| 0012~0013 | 40013~40014 | Reserved | | |
| 0014-0015 | 40015-40016 | Automatic alarm clear | .0 | Target Value Can Not Be 0 |
| | | | .1 | Can Not Run When Weight OFL |
| | | | .2 | Over Zero Range! |
| | | | .3 | Non-Stable |
| | | | .4 | Over/Under Alarm |
| | | | .5 | Beyond Discharge gate Limitation |
| | | | .6 | Reserved |
| | | | .7 | Running, Zero Disabled |
| | | | .8 | Over Zero Range When AutoZero |
| | | | .9 | Automatic zeroing instability |
| | | | .10 | Filler Gate Close Err |
| | | | .11 | DISC Gate Close Err |
| | | | .12 | Fi-Filling Gate Open Width Not be 0 |
| | | | .13 | Me-Filling Gate Open Can Not Narrower Than |

| | | | | |
|------------------|-----------------------------------|--------------------------|-------------------|---|
| | | | | Fi-Filling |
| | | | .14 | Co-Filling Gate Open Can Not Narrower Than Me-Filling |
| | | | .15 | Co-Filling Gate Open Can Not Narrower Than Fi-Filling |
| | | | .16 | Running Stable Timeout |
| 0016~0019 | 40017~40020 | Reserved | | |
| 0020-0021 | 40021-40022 | Manually clear the alarm | .0 | Batch Completed! |
| | | | .1 | Over/Under Pause |
| | | | .2 | Filling Gate Close OverTime t |
| | | | .3 | Bag Lock OT |
| | | | .4 | Bag Unlock OT |
| | | | .5 | DISC Gate Close Overtime |
| | | | .6 | DISC Gate Open OverTime |
| | | | .7 | Reserved |
| | | | .8 | Reserved |
| | | | .9 | Internal Communication Failed |
| | | | .10 | Coarse Flow OT |
| | | | .11 | Medium Flow OT |
| | | | .12 | Manual Fine OT |
| | | | .13 | Discharge OT |
| .14 | Discharge Patting OT | | | |
| .15 | Uncoupled alarm I/O | | | |
| .16 | Hanger rise overtime alarm | | | |
| .17 | Hanger down overtime alarm | | | |
| .18 | Motor mid filling in place alarm | | | |
| .19 | Motor fine filling in place alarm | | | |
| 0022~0025 | 40023~40026 | Reserved | | |
| 0026-0027 | 40027-40028 | Calibration alarm | Capacity Low | |
| | | | Capacity Over | |
| | | | Zero Voltage Over | |
| | | | Zero Voltage Low | |
| | | | Input Unstable | |
| | | | Gain Voltage Over | |
| | | | Gain Voltage Low | |
| | | | Input Unstable | |
| | | | Weight Error | |
| Over Resolution | | | | |

| | | | |
|---|-------------|---|--|
| 0028-0029 | 40029-40030 | Alarm 3 | Reserved |
| (real time paracontrollers)Read only | | | |
| 0030-0031 | 40031-40032 | Total cumulative weight is 6digits | |
| 0032-0033 | 40033-40034 | The total cumulative weight low 9 | |
| 0034-0035 | 40035-40036 | Total accumulated number of packets | |
| 0036-0037 | 40037-40038 | Current formula cumulative weight is 6 digits high | |
| 0038-0039 | 40039-40040 | The current recipe cumulative weight low 9 | |
| 0040-0041 | 40041-40042 | Current formula cumulative number of packages | |
| 0042-0043 | 40043-40044 | User cumulative weight is 6digits | |
| 0044-0045 | 40045-40046 | User cumulative weight is 9digits lower | |
| 0046-0047 | 40047-40048 | User cumulative number of packets | |
| 0048 | 40049 | Batch remaining | |
| 0049 | 40050 | Coarse Flow Timer | |
| 0050 | 40051 | Medium Flow Timer | |
| 0051 | 40052 | Fine Flow Timer | |
| 0052 | 40053 | Result Waiting Timer | |
| 0053 | 40054 | Discharge timer | |
| 0054 | 40055 | Previous package timer (Coarse timer + medium timer +fine timer + Result Waiting timer + Discharge timer + Filling Start Delay timer) | |
| 0055-0056 | 40056-40057 | Previous bag weight | |
| 0057-0058 | 40058-40059 | Packing speed | |
| 0059-0060 | 40060-40061 | Flow rate | |
| 0061 | 40062 | Filling Start Delay | |
| 0062-0099 | 40063-40100 | Reserved | |
| Calibration paracontrollers (reserved 100~200) | | | |
| 0100 | 40101 | unit | Initial value : 1 ; 0 : g , 1 : kg , 2 : t , 3 : lb (lbs) |
| 0101 | 40102 | Decimal point | Initial value:2; Option: 0—0; 1—1 ; 2—2 ; 3—3 ; 4—4 |
| 0102 | 40103 | Resoluti on | Initial value: 1 ; Optional: (1/ 2/ 5/ 10/ 20/ 50) . |
| 0103-0104 | 40104-40105 | Full Scale | Initial value: 10000 ; Write range (maximum range value minimum scale $\leq \times 10\ 0000$, andnot more than 999,999) |
| 0105-0106 | 4010640107 | Zero calibrati on | When writing 1 to the current weight as zero, the weighing is allowed to be written when the weighing platform is stable; the current zero millivolt is returned when reading. |
| 0107-0108 | 40108-40109 | Weight calibration | Enter the standard weight weight (\leq maximum range) ; Read as the current load cellrelative zero millivolts |
| 0109-0110 | 40110-40111 | Weightless Gain Calibration | Write the millivolts corresponding to the gain weight, |

| | | | |
|----------------------------|--------------------|-----------------------------------|--|
| | | (Millivolts) | the controller is temporarily stored; when reading, it returns the absolute millivolts corresponding to the current weight (if the current millivolt is too small or too large, it cannot be calibrated and returns 0XFFFF .). |
| 0111-0112 | 40112-40113 | No code gain calibration (weight) | Write and gain the weight value corresponding to millivolts. Before writing this value, you must first write the gain millivolts. When writing this register, use both to perform gain calibration. Returns 0000H when read . |
| 0113 | 40114 | Load cell sensitivity | 3mV/V |
| 0114-0115 | 40115-40116 | Controller load cell voltage | The multicontroller measures the voltage between EX + and EX - . (Note 2) |
| 0116-0117 | 40117-40118 | Load cell maximum range | Initial value: 10000 ; (Note 2). Write range (maximum range value minimum scale $\leq \times 10\ 0000$, and not more than 999,999) |
| 0118-0119 | 40119-40120 | Filling time | Initial Value:0.0s; Write range:0~99.9s |
| 0120-0121 | 40121-40122 | Material calibration | Write the weight value corresponding to the gain millivolts; Press "manual discharge" to record the current relative millivolt, and use the two to calibrate the gain when writing this register; Return 0000H on read. |
| 0122~0199 | 40123~40200 | Reserved | |
| Weighing paracontroller(1) | | | |
| 0200 | 40201 | Stable range | Initial value : 2 ; Stable range (0 ~9 9 d optional) Unit: d |
| 0201 | 40202 | Stable Timer | Initial value: 0.3 ; range: 0.1~9.9 . (unit s) |
| 0202 | 40203 | Zero Range | Initial value: 50 ; Range : 1 -99 units: % |
| 0203 | 40204 | Zero Track Range | Initial value: 0 ; Range : 0-9 Unit: d |
| 0204 | 40205 | Zero Track Time | Initial value: 2.0 ; range: 0.1~99.9 . (unit s) |
| 0205 | 40206 | Sampling Rate (SPS) | Initial value: 2 ; Optional: 0: 120 times / sec; 1: 240 times / sec; 2: 480 times / sec; 3: 960 times / sec. |
| 0206~0249 | 40207~40250 | Reserved | |

| System and communication paracontrollers - filter paracontrollers | | | |
|---|-------------|---------------------------------------|--|
| 0250 | 40251 | Digital Filter | Initial value: 7 ; Range: 0 to 9 |
| 0251 | 40252 | Advance Filter ON/OFF | Initial value: 0 ; 1 : On 0 : Off |
| 0252 | 40253 | Dynamic Filter | Initial value: 0 ; 1 : On ; 0 : Off |
| 0253 | 40254 | Filling Filter Level | Initial value: 2 ; Range: 0 to 9 |
| 0254 | 40255 | Waiting Process Filter | Initial value: 7 ; Range: 0 to 9 |
| 0255 | 40256 | Discharge Process Filter | Initial value: 1 ; Range: 0 to 9 |
| 0256~0299 | 40257~40300 | Reserved | |
| Weighing paracontroller (3) | | | |
| 0300 | 40301 | Power-Up Zero | Initial value: 0 ; 1 : On ; 0 : Off |
| 0301 | 40302 | Auto Zero Interval | Initial value: 0 ; Range : 0-99 has the bucket to complete the packing and then clear the current weight. |
| 0302 | 40303 | Running Stable Timeout | The initial value is 0 ; the range is 0 to 99.9 . (unit s) |
| 0303 | 40304 | Result Checking Mode | Initial value: 0 ; (range: 0 , 1) 0 : Stable Status ; 1 : Delay Timer |
| 0304 | 40305 | Add to Total When Manual Discharge | Initial value: 0 ; 1 : On ; 0 : Off |
| 0305 | 40306 | Result Holding | Initial value: 0 ; 1 : On ; 0 : Off |
| 0306 | 40307 | Adaptive Level | Initial value: 3 ; Range: 1 ~ 5 |
| 0307 | 40308 | Adaptive ON/OFF | Initial value: 0 ; Range: 0 ~ 2 |
| 0308 | 40309 | Manual clutch ON/OFF | Initial value: 0 ; 1 : On ; 0 : Off |
| 0309 | 40310 | Bracket running control ON/OFF | Initial value: 0 ; 1 : On ; 0 : Off |
| 0310 | 40311 | Hang bag running control ON/OFF | Initial value: 0 ; 1 : On ; 0 : Off |
| 0311 | 40312 | Hang bag OFF logic ON/OFF | Initial value: 0 ; 1 : On ; 0 : Off |
| 0312 | 40313 | Gross weight detect ON/OFF | Initial value: 0 ; 1 : On ; 0 : Off |
| 0313~0349 | 40314~40350 | Reserved | |
| System and communication paracontrollers - structural paracontrollers | | | |
| 0350 | 40351 | Weigher Structure | Initial value: 0 ; 0 : Net Weigher; 1 : Gross Weigher; 2 : PLC mode; 3: Jumbo Bag; 4 : Valve scale. |
| 0351 | 40352 | Working Mode | Initial value : 0 ; 0: single scale; 1: Dual Scale: |

| | | | |
|--|-------------|----------------------------|--|
| | | | Master ;2: Dual Scale: Slave |
| 0352 | 40353 | Mode | Initial value: 1 ; 0 : Gross ; 1 :Net |
| 0353 | 40354 | Hanger Movement Type | Initial value: 0 ; 0 : Air Drive; 1 : Motor Drive |
| 0354 | 40355 | Filling Mode | Initial value: 1 ; 0 : Solo Filling; 1 : Combination Filling |
| 0355 | 40356 | Dual Scale Unlock Bag Mode | Initial value: 0 ; 0 : Asynchro Unlock; 1 : Synchro Unlock1; 2 : Synchro Unlock2. |
| 0356 | 40357 | Holder control ON/OFF | Initial value: 0; 0: OFF; 1: ON |
| 0357~0499 | 40358~40500 | Reserved | |
| Recipe paracontrollers - Value paracontrollers | | | |
| 0500-500 | 40501-40502 | Recipe ID | Initial value 1 ; range: 1 to 20 |
| 0502-0503 | 40503-40504 | Target | Weight value writing range : ≤maximum range |
| 0504-0505 | 40505-40506 | Coarse Flow Remains | |
| 0506-0507 | 40507-40508 | Medium Flow Remains | |
| 0508-0509 | 40509-40510 | Free Fall | |
| 0510-0511 | 40511-40512 | Near Zero Band | |
| 0512-0513 | 40513-40514 | Adaptive Level | Initial value 3 ; range: 1 to 5 |
| 0514-0515 | 40515-40516 | Adaptive ON/OFF | Initial value 0 ; range: 0 to 2 |
| 0516~0549 | 40517~40550 | Reserved | |
| Recipe paracontroller - time paracontroller | | | |
| 0550 | 40551 | Filling Start Delay | Initial value: 0.5 ; range: 0 to99.9 . (unit s) |
| 0551 | 40552 | COMP.Inhibit Timer(Co-F) | Initial value: 09 ; range: 0 to99.9 . (unit s) |
| 0552 | 40553 | COMP.Inhibit Timer(Me-F) | Initial value: 0.9 ; range: 0 to99.9 . (unit s) |
| 0553 | 40554 | COMP.Inhibit Timer(Fi-F) | Initial value: 0.9 ; range: 0 to99.9 . (unit s) |
| 0554 | 40555 | Result Waiting Timer | Initial value: 0.5 ; range: 0 to99.9 . (unit s) |
| 0555 | 40556 | Bag Locked Delay Timer | Initial value: 0.5 ; range: 0 to99.9 . (unit s) |
| 0556 | 40557 | Unlock Bag Pre-Delay Timer | Initial value: 0.5 ; range: 0 to99.9 . (unit s) |
| 0557 | 40558 | Discharge Delay Timer | Initial value: 0.5 ; range: 0 to99.9 . (unit s) |
| 0558~0599 | 40559~40600 | Reserved | |

| Over/Under Paracontroller | | | |
|--|-------------|----------------------------------|---|
| 0600 | 40601 | OVER/UNDER ON/OFF | Initial value: 0 ; 1 : On ; 0 : Off |
| 0601 | 40602 | OVER/UNDER Pause | Initial value: 0 ; 1 : On ; 0 : Off |
| 0602 | 40603 | OVER/UNDER Alarm Timer | Initial value: 10 ; range: 0 ~999 . (unit s) |
| 0603-0604 | 40604-40605 | Over Limit Value | Weight value writing range : \leq maximum range |
| 0605-0606 | 40606-40607 | Under Limit Value | |
| 0607 | 40608 | Compensation ON/OFF | Initial value: 0 ; 1 : On ; 0 : Off. |
| 0608 | 40609 | Compensation Times | First: 1 ; range: 1 ~ 99 . |
| 0609 | 40610 | Flow-ON Times | Initialvalue: 0.5 ; range: 0 to 99 .9 . (unit s) |
| 0610 | 40611 | Flow-OFF Times | Initialvalue: 0.5 ; range: 0 to 99 .9 . (unit s) |
| Auto Free Fall Correction Paracontroller | | | |
| 0611 | 40612 | Auto Free Fall Correction ON/OFF | Initial value: 0 ; 1 : On ; 0 : Off . |
| 0612 | 40613 | Reference Samples PCS | Initial value: 1 ; Range: 1~99 . |
| 0613 | 40614 | Correction Effective Range | Range: 2.0 ; Range: 0 to 9.9 (unit: %) |
| 0614 | 40615 | Correction Percentage | Initial value: 1 ; Optional: 0--100 % correction; 1--5 0% correction; 2 - 25% correction |
| Jog Flow Paracontroller | | | |
| 0615 | 40616 | Jog Flow ON/OFF | Initial value: 0 ; 1 : On; 0 : Off. |
| 0616 | 40617 | Jog Flow-ON Timer | Initial value: 0.5 ; range: 0 to9.9 . (unit s) |
| 0617 | 40618 | Jog Flow-OFF Timer | Initial value: 0.5 ; range: 0 to9.9 . (unit s) |
| Net Weigher Paracontroller | | | |
| 0618 | 40619 | Single scale combination Times | First: 1 ; range: 0 ~ 99 . |
| 0619~0649 | 40620~40650 | Reserved | |
| Gross Weigher Scale Paracontroller | | | |
| 0650 | 40651 | Next Lock Bag Start Delay Time | Initial value: 4.0 ; range: 0 to 99 .9 . (unit s) |
| 0651~0699 | 40652~40700 | Reserved | |
| PLC Paracontroller | | | |
| 0700-0701 | 40701-40702 | PLC-OverLimit Value | 0 ~ Full Scale |

| | | | |
|-----------------------------------|--------------------|----------------------------------|---|
| 0702-0703 | 40703-40704 | PLC-UnderLimit Value | 0 ~ Full Scale |
| 0704-0705 | 40705-40706 | PLC-UpperLimit Value | 0 ~ Full Scale |
| 0706-0707 | 40707-40708 | PLC-LowerLimit Value | 0 ~ Full Scale |
| 0708-0749 | 40709-40750 | Reserved | |
| Jumbo Bag Paracontroller | | | |
| 0750 | 40751 | Hang Up Bag Delay | Initialvalue: 0.5 ; range: 0 to 99.9 . (unit s) |
| 0751 | 40752 | Auto Hanger ON/OFF | Initial value: 0 ; 1 : On ; 0 : Off |
| 0752 | 40753 | Delay Before Hanger Rise | Initial value: 5.0 ; range: 0 ~ 99.9 . (unit s) |
| 0753 | 40754 | Delay Before Hanger Drop | Initial value: 5.0 ; range: 0 ~ 99.9 . (unit s) |
| 0754 | 40755 | Hanger Rise Time Limitation | Initial value: 5.0 ; range: 0 ~ 99.9 . (unit s) |
| 0755 | 40756 | Hanger Drop Time Limitation | Initial value: 5.0 ; range: 0 ~ 99.9 . (unit s) |
| 0756 | 40757 | Fan Rotating Time | Initialvalue: 0.5 ; range: 0 to 99.9 . (unit s) |
| 0757 | 40758 | Decoupled up ON/OFF | Initial value: 0 ; 1 : On; 0 : Off. |
| 0758 | 40759 | Uncoupled alarm ON/OFF | Initial value: 0 ; 1 : On; 0 : Off. |
| 0759 | 40760 | Hang bag reset delay | Initialvalue: 0.0 ; range: 0 to 99.9 . (unit s) |
| 0760 | 40761 | Blow | Initial value: 0. 0: Uplink delay before blowing 1: Uplink delay after blowing |
| 0761 | 40762 | Selection of return valve mode | Initial value: 0; 0: Close the return valve after filling; 1: close the return valve after unlock bag |
| 0762 | 40763 | Second unlink delay | Initialvalue: 0.0 ; range: 0 to 99.9 . (unit s) |
| 0763 | 40764 | Second unlink timer | Initialvalue: 0.0 ; range: 0 to 99.9 . (unit s) |
| 0764 | 40765 | Second uplink pause timer | Initialvalue: 0.0 ; range: 0 to 99.9 . (unit s) |
| 0765 | 40766 | Conveyor reversal timer | Initialvalue: 0.0 ; range: 0 to 99.9 . (unit s) |
| 0766-0767 | 40767-40768 | Weight value of decoupling alarm | 0~maximum range |
| 0768-0799 | 40769-40800 | Reserved | |
| Valve Scale Paracontroller | | | |

| | | | |
|--|-------------|---------------------------|--|
| 0800 | 40801 | Delay Before Lifting Bag | Initialvalue : 0.5 ; range: 0 to 99.9 . (unit s) |
| 0801 | 40802 | Lifting Bag Timer | Initialvalue : 0.5 ; range: 0 to 99.9 . (unit s) |
| 0802 | 40803 | Delay Before Pusing Bag | Initialvalue : 0.5 ; range: 0 to 99.9 . (unit s) |
| 0803 | 40804 | Pushing Bag Timer | Initialvalue : 0.5 ; range: 0 to 99.9 . (unit s) |
| 0804~0999 | 40805~41000 | Reserved | |
| Patting Paracontroller (reserved 1000~1200) | | | |
| 1000 | 41001 | Patting Mode | Initial value: 0 ; Optional: 0 : Disable ; 1 : After Waiting ; 2 : When Filling ; 3: All time . Net Weigher Can Write: 0,1 ; Gross Weigher Can Write: 0~3 . |
| 1001-1002 | 41002-41003 | Start-Up Weight | Initialvalue: 0 ; Range: 0 ~Maximum range. |
| 1003 | 41004 | Patting Times(Filling) | Initial value: 0 ; range: 0~99 . Set the paracontrollers for the number of shots in the fill . |
| 1004 | 41005 | Patting Times(Waiting) | Initial value: 4 ; Range: 0~99 . Set the paracontrollers for the number of shots after the value is set . |
| 1005 | 41006 | Patting Start Delay Timer | Initial value: 0.5 ; range : 0~99.9. (unit s) After the bag is started , the bag output is valid after this delay time. |
| 1006 | 41007 | Patting ON Timer | Initial value: 0.5 ; range: 0~99.9. (unit s) During the on-off cycle of the bag, the bag output valid time. |
| 1007 | 41008 | Patting OFF Timer | Initial value: 0.5 ; range : 0~99.9. (unit s) In the on-off cycle of the bag, the bag output invalid time. |
| 1008 | 41009 | Extra ON Timer | Initialvalue: 0 ; range : 0~99.9 .(unit s) |
| 1009~1019 | 41010~41020 | Reserved | |
| Coding Paracontroller | | | |
| 1020 | 41021 | Coding Device ON/OFF | Initial value: 0 ; 1 : On ; 0 : Off . |
| 1021 | 41022 | Coding Start Delay Timer | Initialvalue: 0.5 ; range: 0 to 99.9 . (unit s) |

| | | | |
|----------------------------------|-------------|--|---|
| 1022 | 41023 | Coding Duration Timer | Initialvalue: 0.5 ; range: 0 to 99.9 . (unit s) |
| 1023 | 41024 | Not Allow Fill/Discharge When Coding | Initial value: 0 ; 0 : The discharge output or the fill output is allowed to start during the coding process; 1 : The discharge output or fill output is not allowed to start during the coding process. |
| 1024~1029 | 41025~41030 | Reserved | |
| Sewing Paracontroller | | | |
| 1030 | 41031 | Sewing Start Delay Timer | Initialvalue: 0.5 ; range: 0 to 99.9 . (unit s) |
| 1031 | 41032 | Sewing ON Timer | Initialvalue: 4.0 ; range: 0 to 99.9 . (unit s) |
| 1032 | 41033 | Cutter ON Timer | Initialvalue: 0.5 ; range: 0 to 99.9 . (unit s) |
| 1033 | 41034 | Sewing Stop Delay | Initialvalue: 0.5 ; range: 0 to 99.9 . (unit s) |
| 1034 | 41035 | Cutter Start Delay | Initialvalue: 0.5 ; range: 0 to 99.9 . (unit s) |
| 1035 | 41036 | Sewing machine ON/OFF | Initialvalue: 0 ; 1 : ON; 0 : OFF |
| 1036 | 41037 | Sewing machine shaking time | Initialvalue: 0.3 ; range: 0~99.9 . |
| 1037~1039 | 41038~41040 | Reserved | |
| Discharge Patting Paracontroller | | | |
| 1040 | 41041 | Discharge Patting ON/OFF | Initial value: 0 ; 1 : On ; 0 : Off . |
| 1041 | 41042 | Discharge ON Timer | Initialvalue: 2.0 ; range: 0 to 9.9 . (unit s) |
| 1042 | 41043 | Discharge Patting ON Timer | Initialvalue: 0.5 ; range: 0 to 9.9 . (unit s) |
| 1043 | 41044 | Discharge Patting OFF Timer | Initialvalue: 0.5 ; range: 0 to 9.9 . (unit s) |
| 1044 | 41045 | Discharge Patting Times | Initial value: 10 ; Range: 0 to 99 . |
| 1045~1049 | 41046~41050 | Reserved | |
| Overtime alarm paracontroller | | | |
| 1050 | 41051 | Overtime Checking ON/OFF | Initial value: 0 ; 1 : On ; 0 : Off . |
| 1051 | 41052 | Coarse Flow Overtime | Initialvalue: 5.0 ; range: 0 to 99.9 . (unit s) |
| 1052 | 41053 | Medium Flow Overtime | Initialvalue: 5.0 ; range: 0 to 99.9 . (unit s) |
| 1053 | 41054 | Manual Fine | Initialvalue: 5.0 ; range: 0 to 99.9 . |

| | | | |
|---------------------------------------|-------------|---------------------------------------|--|
| | | Overtime | (unit s) |
| 1054 | 41055 | Discharge Overtime | Initialvalue: 5.0 ; range: 0 to 99.9 . (unit s) |
| 1055~1059 | 41056~41060 | Reserved | |
| Auxiliary Pulse Paracontroller | | | |
| 1060 | 41061 | Auxiliary Pulse 1 Execute Total Timer | Initial value: 0.0 ; Range: 0 to 999.9 . (unit s) |
| 1061 | 41062 | Auxiliary Pulse 1 ON Timer | Initial value: 10.0 ; Range: 0 to 999.9 . (unit s) |
| 1062 | 41063 | Auxiliary Pulse 1 OFF Timer | Initial value: 10.0 ; Range: 0 to 999.9 . (unit s) |
| 1063 | 41064 | Auxiliary Pulse 2 Execute Total Timer | Initial value: 0.0 ; Range: 0 to 999.9 . (unit s) |
| 1064 | 41065 | Auxiliary Pulse 2 ON Timer | Initial value: 10.0 ; Range: 0 to 999.9 . (unit s) |
| 1065 | 41066 | Auxiliary Pulse 2 OFF Timer | Initial value: 10.0 ; Range: 0 to 999.9 . (unit s) |
| 1066 | 41067 | Auxiliary Pulse 3 Execute Total Timer | Initial value: 0.0 ; Range: 0 to 999.9 . (unit min) |
| 1067 | 41068 | Auxiliary Pulse 3 ON Timer | Initial value: 10.0 ; Range: 0 to 999.9 . (unit min) |
| 1068 | 41069 | Auxiliary Pulse 3 OFF Timer | Initial value: 10.0 ; Range: 0 to 999.9 . (unit min) |
| 1069 | 41070 | Auxiliary Pulse 4 Execute Total Timer | Initial value: 0.0 ; Range: 0 to 999.9 . (unit min) |
| 1070 | 41071 | Auxiliary Pulse 4 ON Timer | Initial value: 10.0 ; Range: 0 to 999.9 . (unit min) |
| 1071 | 41072 | Auxiliary Pulse 4 OFF Timer | Initial value: 10.0 ; Range: 0 to 999.9 . (unit min) |
| 1072 | 41073 | Auxiliary Pulse 1 | Initial value: 0; 0—Pulse Mode , 1—Level Mode |
| 1073 | 41074 | Auxiliary Pulse 2 | |
| 1074 | 41075 | Auxiliary Pulse 3 | |
| 1075 | 41076 | Auxiliary Pulse 4 | |
| 1076 | 41077 | Auxiliary Pulse ON/OFF | Initial value: 0 , 1 : On ; 0 : Off |
| 1077~1079 | 41078~41080 | Reserved | |
| Conveyor Paracontroller | | | |
| 1080 | 41081 | Conveyor ON/OFF | Initial value: 0 ; 1 : On ; 0 : Off . |
| 1081 | 41082 | Conveyor Start Delay Timer | Initialvalue: 0.5 ; range: 0 to 99.9 . (unit s) |

| | | | |
|---|-------------|--------------------------------|---|
| 1082 | 41083 | Conveyor Running Timer | Initialvalue: 4.0 ; range: 0 to 99.9 . (unit s) |
| 1083 | 41084 | Conveyor 2/3 Max running timer | Initialvalue: 30.0 ; range: 0~99.9 |
| 1084~1089 | 41085~41090 | Reserved | |
| Print Paracontroller | | | |
| 1090 | 41091 | Auto Print | Initial value: 0 , 1 : On ; 0 : Off |
| 1091 | 41092 | Printer Format | Initial value : 0 ; 0 : 24 columns printing ; 1 : 32 columns printing . |
| 1092 | 41093 | Printing Language | Initialvalue : 0 ; 0 : Chinese; 1 : E n g l i s h . |
| 1093 | 41094 | Printing Line Nos. | Initial value: 3 ; Range: 0 to 9 . |
| 1094~1199 | 41095~41200 | Reserved | |
| User Logic- 1 (User Logic-1-6 reserved 1200~1400) | | | |
| 1200 | 41201 | Logic Type | Initial value : 0 ; range 0~5 . 0 : CLOSE 1 : Delay on 2 : Delay OFF 3 : Delay ON & Delay OFF 4 : OFF-ON,Edge Trigger 5 : ON-OFF,Edge Trigger |
| 1201 | 41202 | Trigger Define | Initial value : 0 ; range: 0~64 . Can be selected from the definition of the trigger input port , fixed digital input port 1~12 , digital output definition, weight value trigger. |
| 1202 | 41203 | Trigger Input Port | Initial value : 0 ; range 0~12 . Select the digital input port 0~12 corresponding to this function signal , and input port 0 means that this function is not defined. |
| 1203 | 41204 | Output Port | Initial value : 0 ; range 0~16 . Select the digital output port 0~16 corresponding to the function signal , and the output port- 0 means that the function is not defined. |
| 1204 | 41205 | Delay ON Timer | Initial value : 0 ; range: 0~99.9 .(unit s) After the trigger signal is valid, the logic output signal is valid after the delay. |
| 1205 | 41206 | Delay OFF Timer | Initial value : 0 ; range: 0~99.9 .(unit s) |

| | | | |
|---------------|-------------|--------------------|--|
| | | | After the trigger signal is invalid, the logic output signal will be invalid after the delay. |
| 1206 | 41207 | Output ON Timer | Initial value : 0 ; range: 0~99.9 .(unit s) The duration after the logic output signal is valid, and becomes invalid after the end of the time. |
| 1207-1208 | 41208-41209 | Trigger Weight | Initial value: 0 ; Range:0~999999 When the trigger signal selects "Threshold Weight", the current weight is compared to this value. |
| 1209~1219 | 41210~41220 | Reserved | |
| User Logic- 2 | | | |
| 1220 | 41221 | Logic Type | Initial value : 0 ; range 0~5 . 0 : CLOSE 1 : Delay on 2 : Delay OFF 3 : Delay ON & Delay OFF 4 : OFF-ON,Edge Trigger 5 : ON-OFF,Edge Trigger |
| 1221 | 41222 | Trigger Define | Initial value : 0 ; range: 0~64 . Can be selected from the definition of the trigger input port , fixed digital input port1~12 , digital output definition, weight value trigger. |
| 1222 | 41223 | Trigger Input Port | Initial value : 0 ; range 0~12 . Select the digital input port 0~12corresponding to this function signal , and input port 0 means that this function is not defined. |
| 1223 | 41224 | Output Port | Initial value : 0 ; range 0~16 . Select the digital output port0~16 corresponding to the function signal , and the output port- 0 means that the function is not defined. |
| 1224 | 41225 | Delay ON Timer | Initial value : 0 ; range: 0~99.9 .(unit s) After the trigger signal is valid, the logic output signal is valid after the delay. |
| 1225 | 41226 | Delay OFF Timer | Initial value : 0 ; range: 0~99.9 .(unit s) After the trigger signal is invalid, the logic output signal will be invalid after the delay. |

| | | | |
|---------------|-------------|--------------------|--|
| 1226 | 41227 | Output ON Timer | Initial value : 0 ; range: 0~99.9 .(unit s) The duration after the logic output signal is valid, and becomes invalid after the end of the time. |
| 1227-1228 | 41228-41229 | Trigger Weight | Initial value: 0 ; Range: 0~999999 When the trigger signal selects "Threshold Weight", the current weight is compared to this value. |
| 1229~1239 | 41230~41240 | Reserved | |
| User Logic- 3 | | | |
| 1240 | 41241 | Logic Type | Initial value : 0 ; range 0~5 . 0 : CLOSE 1 : Delay on 2 : Delay OFF 3 : Delay ON & Delay OFF 4 : OFF-ON,Edge Trigger 5 : ON-OFF,Edge Trigger |
| 1241 | 41242 | Trigger Define | Initial value : 0 ; range: 0~64 . Can be selected from the definition of the trigger input port , fixed digital input port1~12 , digital output definition, weight value trigger. |
| 1242 | 41243 | Trigger Input Port | Initial value : 0 ; range 0~12 . Select the digital input port 0~12corresponding to this function signal , and input port 0 means that this function is not defined. |
| 1243 | 41244 | Output Port | Initial value : 0 ; range 0~16 . Select the digital output port0~16 corresponding to the function signal , and the output port- 0 means that the function is not defined. |
| 1244 | 41245 | Delay ON Timer | Initial value : 0 ; range: 0~99.9 .(unit s) After the trigger signal is valid, the logic output signal is valid after the delay. |
| 1245 | 41246 | Delay OFF Timer | Initial value : 0 ; range: 0~99.9 .(unit s) After the trigger signal is invalid, the logic output signal will be invalid after the delay. |
| 1246 | 41247 | Output ON Timer | Initial value : 0 ; range: 0~99.9 .(unit s) The duration after the logic output |

| | | | |
|---------------|-------------|--------------------|---|
| | | | signal is valid, and becomes invalid after the end of the time. |
| 1247-1248 | 41248-41249 | Trigger Weight | Initial value: 0 ; range: 0~999999 . When the trigger signal selects "Threshold Weight", the current weight is compared to this value. |
| 1249~1259 | 41250~41260 | Reserved | |
| User Logic- 4 | | | |
| 1260 | 41261 | Logic Type | Initial value : 0 ; range 0~5 . 0 : CLOSE 1 : Delay on 2 : Delay OFF 3 : Delay ON & Delay OFF 4 : OFF-ON,Edge Trigger 5 : ON-OFF,Edge Trigger |
| 1261 | 41262 | Trigger Define | Initial value : 0 ; range: 0~64 . Can be selected from the definition of the trigger input port , fixed digital input port 1~12 , digital output definition, weight value trigger. |
| 1262 | 41263 | Trigger Input Port | Initial value : 0 ; range 0~12 . Select the digital input port 0~12 corresponding to this function signal , and input port 0 means that this function is not defined. |
| 1263 | 41264 | Output Port | Initial value : 0 ; range 0~16 . Select the digital output port 0~16 corresponding to the function signal , and the output port- 0 means that the function is not defined. |
| 1264 | 41265 | Delay ON Timer | Initial value : 0 ; range: 0~99.9 .(unit s) After the trigger signal is valid, the logic output signal is valid after the delay. |
| 1265 | 41266 | Delay OFF Timer | Initial value : 0 ; range: 0~99.9 .(unit s) After the trigger signal is invalid, the logic output signal will be invalid after the delay. |
| 1266 | 41267 | Output ON Timer | Initial value : 0 ; range: 0~99.9 .(unit s) The duration after the logic output signal is valid, and becomes invalid after the end of the time. |

| | | | |
|----------------------|-------------|--------------------|--|
| 1267-1268 | 41268-41269 | Trigger Weight | Initial value: 0 , range: 0~999999 . When the trigger signal selects "Threshold Weight", the current weight is compared to this value. |
| 1269~1279 | 41270~41280 | Reserved | |
| User Logic- 5 | | | |
| 1280 | 41281 | Logic Type | Initial value: 0 ; range 0~5 . 0 : CLOSE 1 : Delay on 2 : Delay OFF 3 : Delay ON & Delay OFF 4 : OFF-ON,Edge Trigger 5 : ON-OFF,Edge Trigger |
| 1281 | 41282 | Trigger Define | Initial value : 0 ; range: 0~64 . Can be selected from the definition of the trigger input port , fixed digital input port 1~12 , digital output definition, weight value trigger. |
| 1282 | 41283 | Trigger Input Port | Initial value : 0 ; range 0~12 . Select the digital input port 0~12 corresponding to this function signal , and input port 0 means that this function is not defined. |
| 1283 | 41284 | Output Port | Initial value : 0 ; range 0~16 . Select the digital output port 0~16 corresponding to the function signal , and the output port- 0 means that the function is not defined. |
| 1284 | 41285 | Delay ON Timer | Initial value : 0 ; range: 0~99.9 .(unit s) After the trigger signal is valid, the logic output signal is valid after the delay. |
| 1285 | 41286 | Delay OFF Timer | Initial value : 0 ; range: 0~99.9 .(unit s) After the trigger signal is invalid, the logic output signal will be invalid after the delay. |
| 1286 | 41287 | Output ON Timer | Initial value : 0 ; range: 0~99.9 .(unit s) The duration after the logic output signal is valid, and becomes invalid after the end of the time. |
| 1287-1288 | 41288-41289 | Trigger Weight | Initialvalue: 0 ; Range: 0~Maximum range. When the trigger signal selects |

| | | | |
|----------------------|-------------|--------------------|--|
| | | | "Threshold Weight", the current weight is compared to this value. |
| 1289~1299 | 41290~41300 | Reserved | |
| User Logic- 6 | | | |
| 1300 | 41301 | Logic Type | Initial value: 0 ; range 0~5 . 0 : CLOSE 1 : Delay on 2 : Delay OFF 3 : Delay ON & Delay OFF 4 : OFF-ON,Edge Trigger 5 : ON-OFF,Edge Trigger |
| 1301 | 41302 | Trigger Define | Initial value: 0 ; range: 0~64 . Can be selected from the definition of the trigger input port, fixed digital input port 1~12 , digital output definition, weight value trigger. |
| 1302 | 41303 | Trigger Input Port | Initial value: 0 ; range 0~12 . Select the digital input port 0~12 corresponding to this function signal, and input port 0 means that this function is not defined. |
| 1303 | 41304 | Output Port | Initial value: 0 ; range 0~16 . Select the digital output port 0~16 corresponding to the function signal, and the output port- 0 means that the function is not defined. |
| 1304 | 41305 | Delay ON Timer | Initial value : 0 ; range: 0~99.9 .(unit s) After the trigger signal is valid, the logic output signal is valid after the delay. |
| 1305 | 41306 | Delay OFF Timer | Initial value : 0 ; range: 0~99.9 .(unit s) After the trigger signal is invalid, the logic output signal will be invalid after the delay. |
| 1306 | 41307 | Output ON Timer | Initial value : 0 ; range: 0~99.9 .(unit s) The duration after the logic output signal is valid, and becomes invalid after the end of the time. |
| 1307-1308 | 41308-41309 | Trigger Weight | Initial value: 0 ; range: 0~999999 . When the trigger signal selects "Threshold Weight", the current weight is compared to this value. |
| 1309~1399 | 41310~41400 | Reserved | |

| Motor paracontrollers - filling mode (reserved 1400~1600) | | | |
|--|-------------|-------------------------------|--|
| 1400 | 41401 | Current Filler Motor Cfg ID | Initial value: 0 ; Range: 0~4 |
| 1401 | 41402 | Filling Mode | Initial value : 0 ; Optional: 0 : Air Drive ; 1 : Step Motor Drive; 2 : Motor Drive. |
| 1402 | 41403 | Filler Gate Close Overtime | Initial value: 4.0 ; range: 0~99.9 . (unit s) |
| 1403 | 41404 | Filler Gate Limit Signal Type | Initial value: 0 ; Optional: 0 : In Position When Have Signal; 1 : In Position When No Signal |
| 1404 | 41405 | Filler Motor Cfg ID | Initial value: 0 , range: 0~4 |
| 1405 | 41406 | Filler Motor Frequency | Initialvalue : 12000 , range: 1~50000Hz |
| 1406-1407 | 41407-41408 | Steps For Filler Open to Fi-F | Initialvalue : 1800 ; range: 1~60000 . |
| 1408-1409 | 41409-41410 | Steps For Filler Open to Me-F | Initialvalue : 4300 ; range: 1~60000 . |
| 1410-1411 | 41411-41412 | Steps For Filler Open to Co-F | Initialvalue : 7750 ; range: 1~60000 . |
| 1412 | 41413 | Filler Motor DR | Initial value : 0 ; Optional: 0 : Gate Open When Signal ON ; 1 : Gate Open When Signal OFF |
| 1413 | 41414 | Filler Motor Start Frequency | Initial value : 2000 ; Range: 0~50000Hz (This value should preferably not be greater than the filling motor frequency) |
| 1414 | 41415 | Filler Motor ACC Time | Fill motor acceleration time Initial value: 200 ; Range: 0~9999 . (unit s) |
| 1415 | 41416 | Filler Motor DEC Time | Fill motor deceleration time Initial value: 50 ; Range: 0~9999 . (in ms) |
| 1416 | 41417 | Co-F,Gate Open Time | Initial value: 0.80 ; Range: 0~99.99 . (unit s) |
| 1417 | 41418 | Me-F,Gate Open Time | Initial value: 0.40 ; Range: 0~99.99 . (unit s) |
| 1418 | 41419 | Fi-F,Gate Open Time | Initial value: 0.20 ; Range: 0~99.99 . (unit s) |
| 1419 | 41420 | Lock Mode | Initial value: 0 ; Optional: 0 : Air Drive |

| | | | |
|-----------|-------------|-----------------------------------|---|
| | | | 1 : Step Motor Drive 2 : MotorDrive Dual-Limit; 3 : MotorDrive Single-Limit . |
| 1420 | 41421 | Bag Release Overtime | Initial value: 3.0 ; Range: 0 ~ 99.9 . (unit s) |
| 1421 | 41422 | Bag Lock Overtime | Initial value: 3.0 ; range: 0~99.9 . (unit s) |
| 1422 | 41423 | Clutch Limit Signal Type | Initial value: 0 ;Optional: 0 : In Position When Have Signal 1 : In Position When No Signal. |
| 1423 | 41424 | Clutch Lock Frequency | Initial value: 30000 ; Range: 1~50000 Hz . |
| 1424 | 41425 | Clutch Release Frequency | Initial value: 20000 ; range: 1~50000 Hz . |
| 1425-1426 | 41426-41427 | Steps to Lock Bag | Initial value: 12000 ; range: 1~60000 . |
| 1427 | 41428 | Clutch Motor DR | Initial value: 0 ; Optional: 0 : Lock Bag When Signal OFF; 1 : Lock Bag When Signal ON. |
| 1428 | 41429 | Clutch Motor Start Frequency | Initial value: 2000 ; range: 0 ~ 50000 Hz . (This value cannot be greater than the pocket frequency) |
| 1429 | 41430 | Clutch Motor ACC Time | Initial value: 200 ; Range: 0~9999 . (in ms) |
| 1430 | 41431 | Clutch Motor DEC Time | Initial value: 50 ; Range: 0~9999 (in ms) . |
| 1431 | 41432 | Bag Release Time | Initial value: 0.5 , range: 0~99.99 . (unit s) |
| 1432 | 41433 | Discharge mode | Initial value: pneumatic mode; 0 , Air Drive; 1 . Step Motor Drive 2 , MotorDrive Single-Limit; 3 , MotorDrive Dual-Limit; 4 . MotorDrive Rotating. |
| 1433 | 41434 | DISC Gate Close Overtime | Initial value: 3.0 ; range: 0 ~ 99.9 . (unit s) |
| 1434 | 41435 | DISC Gate Open Overtime | Initial value : 3.0 ; range: 0 ~ 99.9 . (unit s) |
| 1435 | 41436 | DISC Gate Limit Signal Type | Initial value: 0 ; Optional: 0 , In Position When Have Signal. 1 . In Position When No Signal. |
| 1436 | 41437 | Realtime Detecting When Discharge | Initial value : 0 ; 0 : off ; 1 : on. |
| 1437 | 41438 | DISC Motor Open | Initial value : 30000 ; |

| | | | |
|---|--------------------|---|---|
| | | Frequency | range: 1~50000 (Hz) . |
| 1438 | 41439 | DISC Motor Close Frequency | Initial value : 20000 ; range: 1~50000 (Hz) . |
| 1439-1440 | 41440-41441 | Discharge Steps | Initial value : 12000 ; range: 1~60000 . |
| 1441 | 41442 | DISC Motor DR | Initial value : 0 ; Optional: 0 : Gate Open When Signal OFF 1 : Gate Open When Signal ON |
| 1442 | 41443 | DISC Motor Start Frequency | Initial value: 2000 ; range: 1~50000 |
| 1443 | 41444 | DISC Motor ACC Time | Initial value: 200 ; range: 0~9999 |
| 1444 | 41445 | DISC Motor DEC Time | Initial value: 50 ; range: 0~9999 |
| 1445 | 41446 | DISC Gate Open Timer | Initial value: 1.00 ; range: 0~99.99 |
| 1446 | 41447 | Filling motor returns to zero frequency | Initial value: 20000 ; range: 0~50000 |
| 1447 | 41448 | Unlock bag motor power back to zero frequency | Initialvalue: 20000 ; range: 0~50000 |
| 1448 | 41449 | Discharging motor power back to the original zero frequency | Initial value : 20000 ; range: 0~50000 |
| 1449~1599 | 41450~41600 | Reserved | |
| Communication paracontrollers - serial port 2 paracontrollers (reserved 1600~1700) 485 | | | |
| 1600 | 41601 | Communication ID | Initial value: 1 ; 1 ~ 9 9 optional. |
| 1601 | 41602 | Communication Mode | 0 : Modbus-RTU ; 1 : Printing Mode 2 : continuous mode 3 : MD-R (compatible with 01. version) |
| 1602 | 41603 | Baud rate | 0 : 9600 ; 1 : 119200 2 : 38400 ; 3 : 57600 4 : 115200 |
| 1603 | 41604 | Data Format | Communication data format selection (data bit, parity bit, stop bit. E : even parity; N : no parity) 0 : 8-E-1 ; 1 : 8-N-1 2 : 7-E-1 ; 3 : 7-N-1 |
| 1604 | 41605 | Dword Format | Initial value : 0 ; Range : 0-1 0 : AB-CD ; 1 : CD-AB. |
| Communication paracontrollers - serial port 1 paracontrollers 232 | | | |

| | | | |
|---|-------------|---------------------------------|---|
| 1605 | 41606 | Communication ID | Initial value: 1 ; 1 ~ 9 9 optional. |
| 1606 | 41607 | Communication Mode | 0 : Modbus-RTU ; 1 : Printing Mode 2 : continuous mode 3 : MD-R (compatible with 01. version) |
| 1607 | 41608 | Baud rate | 0 : 9600 ; 1 : 119200 2 : 38400 ; 3 : 57600 4 : 115200 |
| 1608 | 41609 | Data Format | Communication data format selection (data bit, parity bit, stop bit. E : even parity; N : no parity) 0 : 8-E-1 ; 1 : 8-N-1 2 : 7-E-1 ; 3 : 7-N-1 |
| 1609 | 41610 | Dword Format | Initial value : 0 ; Range : 0-1 0 : AB-CD ; 1 : CD-AB . |
| Communication paracontrollers - Ethernet Interface paracontrollers | | | |
| 1610 | 41611 | Dword Format | Initial value : 0 ; Range : 0-1 0 : AB-CD ; 1 : CD-AB . |
| 1611 | 41612 | Server Port | Initial value: 502 ; Range: 1 ~ 65535 |
| 1612 | 41613 | IP-address | Initial value: 192.168.1 01. 246 . Range: 0 ~ 255 . |
| 1613 | 41614 | | |
| 1614 | 41615 | | |
| 1615 | 41616 | | |
| 1616~1699 | 41617~41700 | Reserved | |
| I/O Module custom paracontrollers (reserved 1800~1900) | | | |
| 1700 | 41701 | Digital input port 1 definition | Write the corresponding value of the function.If the input port 3 is defined as running, write 1 at address 41703 (refer to 4.8.1 output and input definition table code for numeric function code) Read: return the current switching value custom state |
| 1701 | 41702 | Digital input port 2 definition | |
| 1702 | 41703 | Digital input port 3 definition | |
| 1703 | 41704 | Digital input port 4 definition | |
| 1704 | 41705 | Digital input port 5 definition | |
| 1705 | 41706 | Digital input port 6 definition | |
| 1706 | 41707 | Digital input port 7 definition | |
| 1707 | 41708 | Digital input port 8 definition | |
| 1708 | 41709 | Digital input port 9 definition | |

| | | | |
|------|-------|----------------------------------|--|
| 1709 | 41710 | Digital input port 10 definition | Write the corresponding value of the function. If the output port 3 is defined as running, write 1 at address 41715 (refer to 4.8.1 output and input definition table code for numeric function code). |
| 1710 | 41711 | Digital input port 11 definition | |
| 1711 | 41712 | Digital input port 12 definition | |
| 1712 | 41713 | ON/OFF output port 1 definition | |
| 1713 | 41714 | ON/OFF output port 2 definition | |
| 1714 | 41715 | ON/OFF output port 3 definition | |
| 1715 | 41716 | ON/OFF output port 4 definition | |
| 1716 | 41717 | ON/OFF output port 5 definition | |
| 1717 | 41718 | ON/OFF output port 6 definition | |
| 1718 | 41719 | ON/OFF output port 7 definition | |
| 1719 | 41720 | ON/OFF output port 8 definition | |
| 1720 | 41721 | ON/OFF output port 9 definition | |
| 1721 | 41722 | ON/OFF output port 10 definition | |
| 1722 | 41723 | ON/OFF output port 11 definition | |
| 1723 | 41724 | ON/OFF output port 12 definition | |
| 1724 | 41725 | ON/OFF output port 13 definition | |
| 1725 | 41726 | ON/OFF output port 14 definition | |
| 1726 | 41727 | ON/OFF output port 15 definition | |
| 1727 | 41728 | ON/OFF output port 16 definition | |
| 1728 | 41729 | Start / end ON/OFF test | write: The stop state can be written. Write 1 to start the ON/OFF test. Write 0 to exit the ON/OFF test state. |
| 1729 | 41730 | Input test | Write: not allowed to write Read: From the low to the high, the corresponding port IN1~12 input. 1 is valid for input, 0 is invalid for |

| | | | |
|---|-------------|-------------------|--|
| | | | input. |
| 1730-1731 | 41731-41732 | Output test | <p>Write: The ON/OFF test ON/OFF can be written in the open state, and the output from the low to the high port corresponds to the port OUT1~16. 1 is valid for output, 0 is invalid for output.</p> <p>Read: Returns the status of the current output ON/OFF port, from the low to the high, respectively, corresponding to the port OUT1~16 output. 1 is valid for output, 0 is invalid for output.</p> |
| 1732~1799 | 41733~41800 | Reserved | |
| Other paracontroller settings (reserved 1900~2000) | | | |
| 1800 | 41801 | Print Total ACUM | <p>Read as 0</p> <p>Write 1 , Print Total ACUM</p> |
| 1801 | 41802 | Print recipe ACUM | <p>Read as 0</p> <p>Write 100 to print the current recipe ACUM</p> <p>Write 1-20 , print the corresponding formula ACUM</p> <p>Write 101 to Print All Recipe ACUM</p> |
| 1802 | 41803 | Print user ACUM | <p>Read as 0</p> <p>Write 100 to Print Choose User ACUM</p> <p>Write 0-9 , print the corresponding user ACUM</p> <p>Write 101 , Print All User ACUM</p> |
| 1803 | 41804 | reset | <p>8800 Reset All(Including Calibration)</p> <p>8801 Reset All(Except Calibration)</p> <p>8802 Reset Recipe Paracontroller</p> <p>8803 Reset Sys&Com Paramter</p> <p>8804 Reset Peripherals Paracontroller</p> <p>8805 Reset Motor Paracontroller</p> <p>880 6 Reset Calibration Paracontroller</p> <p>880 7 Reset I/O Module</p> <p>880 8 Reset User Logic Paracontroller 8809 Reset communicate paracontroller</p> |
| 1804 | 41805 | backup | <p>read:</p> <p>0: No Backup Data;</p> <p>1: Have Backup Data.</p> <p>write:</p> |

| | | | |
|---|--------------------|--|---|
| | | | Write 9900 to Execute Paracontroller Backup; Write 9901 to Execute Recovery From Backup Write 9902 to p Execute Delete Backup. |
| 1805-1806 | 41806-41807 | Backup date | Read only |
| 1807-1808 | 41808-41809 | Backup time | |
| 1809 | 41810 | year | 0-99 |
| 1810 | 41811 | month | 1-12 |
| 1811 | 41812 | day | 1-31 |
| 1812 | 41813 | Time | 0-23 |
| 1813 | 41814 | Minute | 0-59 |
| 1814 | 41815 | second | 0-59 |
| 1815 | 41816 | Clear All Recipes ACUM | Write 1 clear total accumulation |
| 1816 | 41817 | Clear recipe ACUM | Write 1-20 to clear the Recipe ID ACUM; Write 100 to Clear Choose Recipe ACUM; Write 101 to Clear All Recipe ACUM. |
| 1817 | 41818 | Clear user ACUM | Read as 0 . Write 0-9 to clear the user ID ACUM ; Write 100 to clear choose user ACUM ; Write 101 to clears all user ACUM. |
| 1818 | 41819 | User ID | Read out current ID, paracontroller ready only |
| 1819-1949 | 41820-41950 | Reserved | |
| Batch setting | | | |
| 1950 | 41951 | Batch | Initial value: 0 ; range: 0~9999 . |
| 1951 | 41952 | Remain PCS | Read only |
| 1952~1999 | 41953~42000 | Reserved | |
| Formula target value (reserved 2000~2300) | | | |
| 2000-2001 | 42001-42002 | Recipe 1 target | Initial value: 0 . |
| 2002-2003 | 42003-42004 | Recipe 2 target | Initial value: 0 . |
| | | | Initial value: 0 . |
| 2038-2039 | 42039-42040 | Recipe 20 target | Initial value: 0 . |
| Cumulative weight | | | |
| 2040-2041 | 42041-42042 | Total cumulative weight is 6 digits | |
| 2042-2043 | 42043-42044 | The total cumulative weight low 9 | |
| 2044-2045 | 42045-42046 | Total accumulated number of packets | |

| | | |
|---|-------------|--|
| 2046-2047 | 42047-42048 | Formula 1 cumulative weight is 6 digits high |
| 2048-2049 | 42049-42050 | Formulation 1 cumulative weight low 9 |
| 2050-2051 | 42051-42052 | Formula 1 cumulative count |
| | | |
| 2160-2161 | 42161-42162 | Formulation 6 High 20 cumulative weight |
| 2162-2163 | 42163-42164 | Formulation 20 cumulative weight low 9 |
| 2164-2165 | 42165-42166 | Formula 20 cumulative times |
| User cumulative weight and number of times | | |
| 2166-2167 | 42167-42168 | User 0 cumulative weight is 6 digits high |
| 2168-2169 | 42169-42170 | User 0 cumulative weight is 9 digits lower |
| 2170-2171 | 42171-42172 | User 0 cumulative times |
| 2172-2173 | 42173-42174 | User 1 cumulative weight is 6 digits high |
| 2174-2175 | 42175-42176 | User 1 cumulative weight is 9 digits lower |
| 2176-2177 | 42177-42178 | User 1 cumulative times |
| 2178-2179 | 42179-42180 | User 2 cumulative weight is 6 digits high |
| 2180-2181 | 42181-42182 | User 2 cumulative weight is 9 digits lower |
| 2182-2183 | 42183-42184 | User 2 cumulative times |
| 2184-2185 | 42185-42186 | User 3 cumulative weight is 6 digits high |
| 2186-2187 | 42187-42188 | User 3 cumulative weight is 9 digits lower |
| 2188-2189 | 42189-42190 | User 3 cumulative times |
| 2190-2191 | 42191-42192 | User 4 cumulative weight is 6 digits high |
| 2192-2193 | 42193-42194 | User 4 cumulative weight is 9 digits lower |
| 2194-2195 | 42195-42196 | User 4 cumulative times |
| 2196-2197 | 42197-42198 | User 5 cumulative weight is 6 digits high |
| 2198-2199 | 42199-42200 | User 5 cumulative weight is 9 digits lower |
| 2200-2201 | 42201-42202 | User 5 cumulative times |
| 2202-2203 | 42203-42204 | User 6 cumulative weight is 6 digits high |
| 2204-2205 | 42205-42206 | User 6 cumulative weight is 9 digits lower |
| 2206-2207 | 42207-42208 | User 6 cumulative times |
| 2208-2209 | 42209-42210 | User 7 cumulative weight is 6 digits high |
| 2210-2211 | 42211-42212 | User 7 cumulative weight is 9 digits lower |
| 2212-2213 | 42213-42214 | User 7 cumulative times |
| 2214-2215 | 42215-42216 | User 8 cumulative weight is 6 digits high |
| 2216-2217 | 42217-42218 | User 8 cumulative weight is 9 digits lower |
| 2218-2219 | 42219-42220 | User 8 cumulative times |
| 2220-2221 | 42221-42222 | User 9 cumulative weight is 6 digits high |
| 2222-2223 | 42223-42224 | User 9 cumulative weight is 9 digits lower |
| 2224-2225 | 42225-42226 | User 9 cumulative times |
| 2226-2299 | 42227-42300 | Reserved |

| Compile information (reserved 9000~9100) | | | |
|---|--------------|---|--|
| 9000-9001 | 49001-49002 | Logic Version | For example : 0 1000 0 |
| 9002-9003 | 49003-49004 | Logic Compile Date | For example : 161201 |
| 9004-9005 | 49005-49006 | Logic Compile Time | For example : 130805 |
| 9006-9007 | 49007-49008 | IO Board Version | For example : 100 |
| 9008~9099 | 49009~49100 | Reserved (reserved 9100~9200) | |
| Coil address (reserved 0~100) | | | |
| 0 | 00001 | Start | Write : FF00H =Valid (Only write FF00H) ; Read: 0001H = On 0000H = Off |
| 1 | 00002 | Emergency stop | |
| 2 | 00003 | stop | |
| 3 | 00004 | Pause | |
| 4 | 00005 | Zeroing | |
| 5 | 00006 | Clear Alarm | |
| 6 | 00007 | Lock/Unlock Request | |
| 7 | 00008 | Change Recipe | |
| 8 | 00009 | Manual Fine Flow | |
| 9 | 00010 | Manual Coarse Flow | |
| 10 | 00011 | Manual Discharge | |
| 11 | 00012 | Manual Empty Material | |
| 12 | 00013 | Hanging bag | |
| 13 | 00014 | Sewing Input | |
| 14 | 00015 | Sewing Emergency Stop | |
| 15 | 00016 | Auxiliary PU Input 1 | |
| 16 | 00017 | Auxiliary PU Input 2 | |
| 17 | 00018 | Auxiliary PU Input 3 | |
| 18 | 00019 | Auxiliary PU Input14 | |
| 19 | 00020 | Clear For Adaptive | |
| 20 | 00021 | Manual Medium Flow | This address can only be written to 1. Read 1 is valid, 0 is invalid. |
| 21 | 00022 | Manual Flow(Only for material Calibration) | This address can only be written to 1. Read 1 is valid, 0 is invalid. |
| 22 | 00023 | Manual Discharge(Only for material Calibration) | This address can only be written to 1. Read 1 is valid, 0 is invalid. |
| ... | ... | Reserved | |

| | | | |
|---|-------|--|---|
| 80 | 00081 | Clear Choose user ACUM | Write: FF00H = valid; Read 0000H . |
| 81 | 00082 | Clear all users ACUM | |
| 82 | 00083 | Clear Choose Repice ACUM | |
| 83 | 00084 | Clear all Repice ACUM | |
| 84 | 00085 | Clear Total ACUM | |
| ... | ... | Reserved | |
| 100 | 00101 | Reset All | Write: FF00H = valid; Read 0000H . Run time can write but not effective, need stop run then write valid |
| 101 | 00102 | Reset Calibration | |
| 102 | 00103 | Reset Sys&Com Paracontroller (not including communication paracontrollers) | |
| 103 | 00104 | Reset Recipe Paracontroller | |
| 104 | 00105 | Reset Peripherals Paracontroller | |
| 105 | 00106 | Reset I/O Module | |
| 106 | 00107 | Reset Motor Paracontroller | |
| 107 | 00108 | Reset User Logic Paracontroller | |
| 108 | 00109 | Execute Paracontroller Backup | |
| 109 | 00110 | Execute Recovery From Backup | |
| 110 | 00111 | Execute Delete Backup | Write: FF00H = delet back up paracontroller read: 0001H =have back up paracontroller; 0000H =no back up paracontroller. |
| 111 | 00112 | Communication paracontroller reset | Write: FF00H = valid; Read 0000H Writable at run time but not effective, need to stop running to write effective. |
| Coil ON/OFF test (reserved 200~250) | | | |
| 150 | 00151 | IO test ON/OFF: Write: FF00H = valid; 0000H = invalid Read: 0001H = valid; 0000H = invalid | |
| 151 | 00152 | Input port 1 | Write invalid Read : 0001H = valid ; 0000H =invalid (When input port is valid, address read out 1) |
| 152 | 00153 | Input port 2 | |
| 153 | 00154 | Input port 3 | |
| 154 | 00155 | Input port 4 | |
| 155 | 00156 | Input port 5 | |

| | | | | |
|-----|-------|----------------|--|---|
| 156 | 00157 | Input port 6 | | |
| 157 | 00158 | Input port 7 | | |
| 158 | 00159 | Input port 8 | | |
| 159 | 00160 | Input port 9 | | |
| 160 | 00161 | Input port 10 | | |
| 161 | 00162 | Input port 11 | | |
| 162 | 00163 | Input port 12 | | |
| 163 | 00164 | Output port 1 | | Read: FF00H = valid; 0000H = invalid (When write FF00H , corresponding port to the address shall be valid) Read: 0001H = valid; 0000H = invalid |
| 164 | 00165 | Output port 2 | | |
| 165 | 00166 | Output port 3 | | |
| 166 | 00167 | Output port 4 | | |
| 167 | 00168 | Output port 5 | | |
| 168 | 00169 | Output port 6 | | |
| 169 | 00170 | Output port 7 | | |
| 170 | 00171 | Output port 8 | | |
| 171 | 00172 | Output port 9 | | |
| 172 | 00173 | Output port 10 | | |
| 173 | 00174 | Output port 11 | | |
| 174 | 00175 | Output port 12 | | |
| 175 | 00176 | Output port 13 | | |
| 176 | 00177 | Output port 14 | | |
| 177 | 00178 | Output port 15 | | |
| 178 | 00179 | Output port 16 | | |

Note 2: The controller will perform the weightless gain calibration according to the currently stored load cell power supply voltage, load cell sensitivity, and load cell maximum range (where the maximum range input cannot be greater than the maximum range set in the controller calibration (modbus addresses 10104 and 40105).
Calibration principle:

Zero calibration: Zero calibration can be performed via modbus (40106 and 40107) addresses. (If you skip the zero calibration and directly perform the weightless gain calibration, the last recorded zero will be used as the current zero calibration)
Gain calibration: Gain millivolts is the input load cell power multiplied by the load cell sensitivity, and the gain weight is the load cell's maximum range. The gain millivolts and gain weight used for gain scaling here are referenced below.

The first type of weightless gain calibration method: when the load cell power supply (5000mv) is input separately, the weightless calibration operation will be directly performed.

The second type of weightless gain calibration method: input load cell sensitivity (2mv/v) and input the load cell's maximum range (1000kg) will carry out the

weightless calibration operation (note here, please input only the load cell sensitivity or only input the maximum When the range is measured, the entered value is not saved immediately. Only when both values are entered and the two values entered are reasonable, the data is saved and then the gain calibration is performed.

7. Automatic bagging process

The GM9907 bagging controller automatically controls the entire bagging process of coarse, medium and fine filling and unloading in the automatic bagging state. Supports a variety of modes including bucket, bucketless scale, ton pack scale, valve port scale and PLC. The scale structure and working mode are selected in the system and communication paracontrollers.

7.1 With a single scale Net Weigher

In this mode, the material is fed from the preparation hopper to the measuring hopper through the filling mechanism (coarse, medium and fine), and the weight sampling of the controlling control process is completed in the measuring hopper (the weighing load cell is mounted on the measuring hopper). After the controlling is completed, the material is discharged into the package through the unloading mechanism on the measuring hopper. Its structure is shown in the following figure:

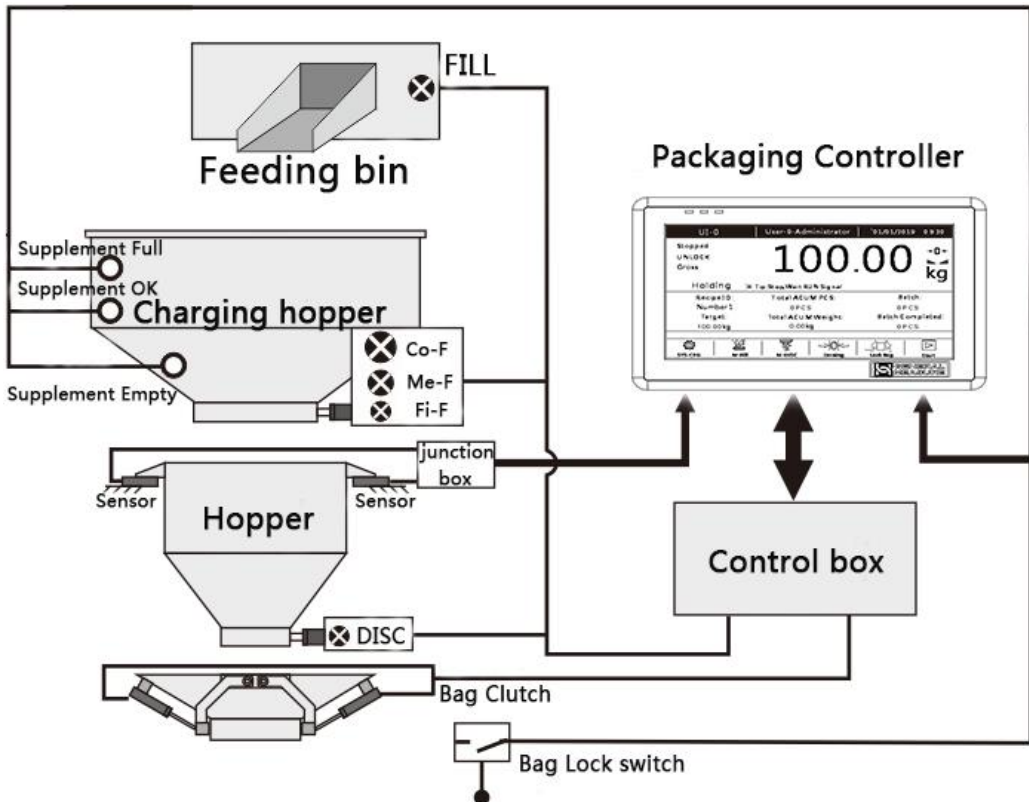

Basic process description:

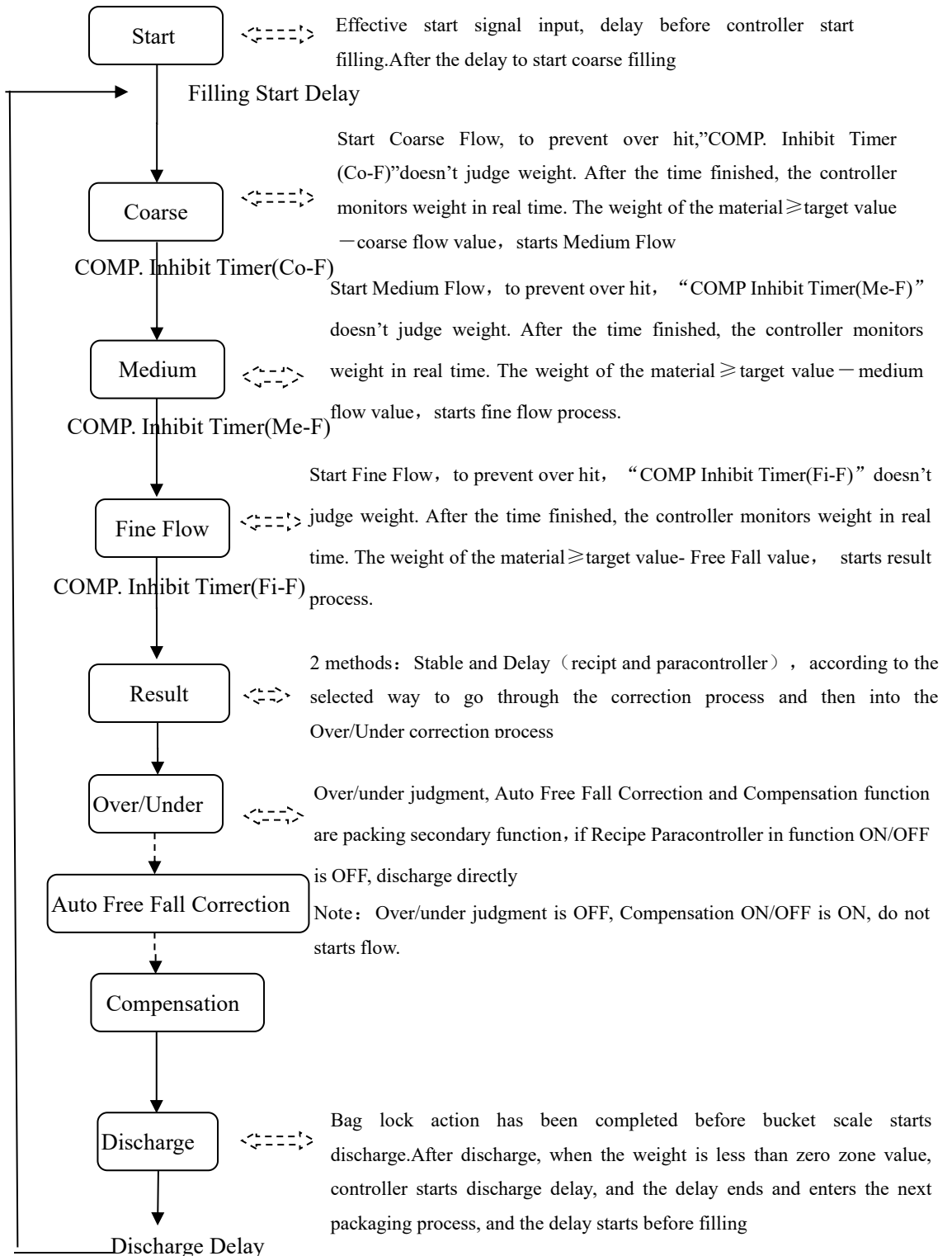

7.2 Without a single scale Gross Weigher

In this mode, the material is directly fed into the package from the hopper through the filling mechanism (coarse, medium, and fine), and the weight sampling of the controlling control process is completed in the package (the weighing load cell is mounted on the hopper). After the controlling is completed, the controller controls the unlock bag directly. Its structure is shown in the following figure:

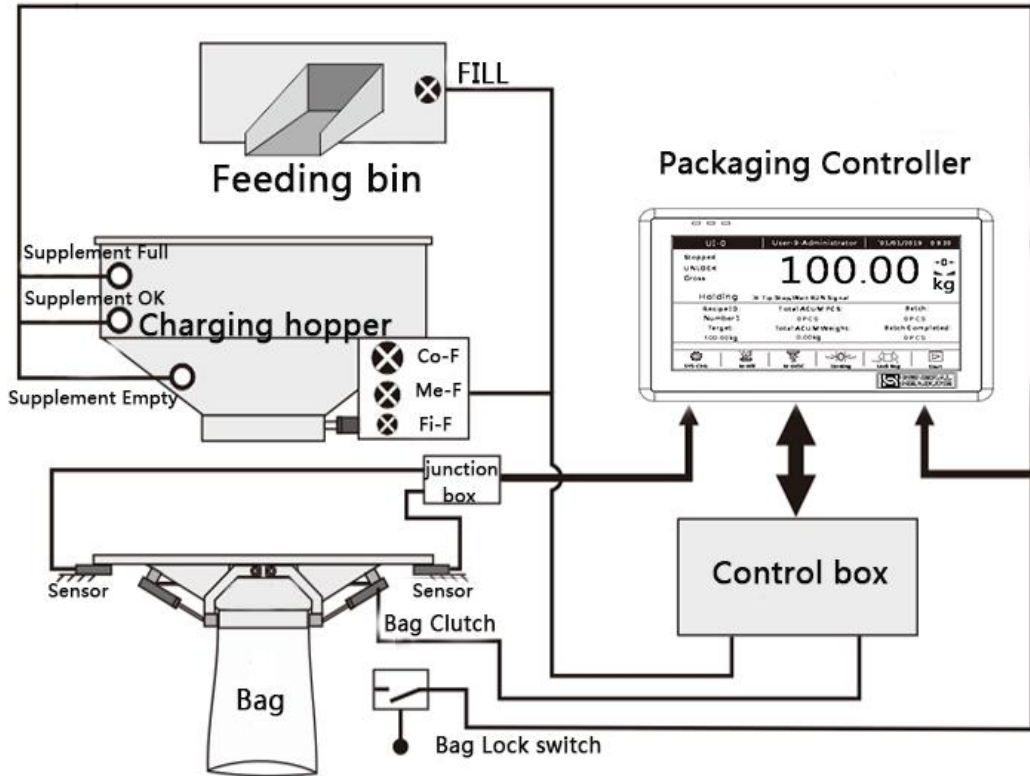

The difference between the Gross Weigher process and the Net Weigher process is that the load cell is installed on the hopper. After starting, it is necessary to complete the bag clamping action before starting the filling delay and starting the filling process.

Basic process description:

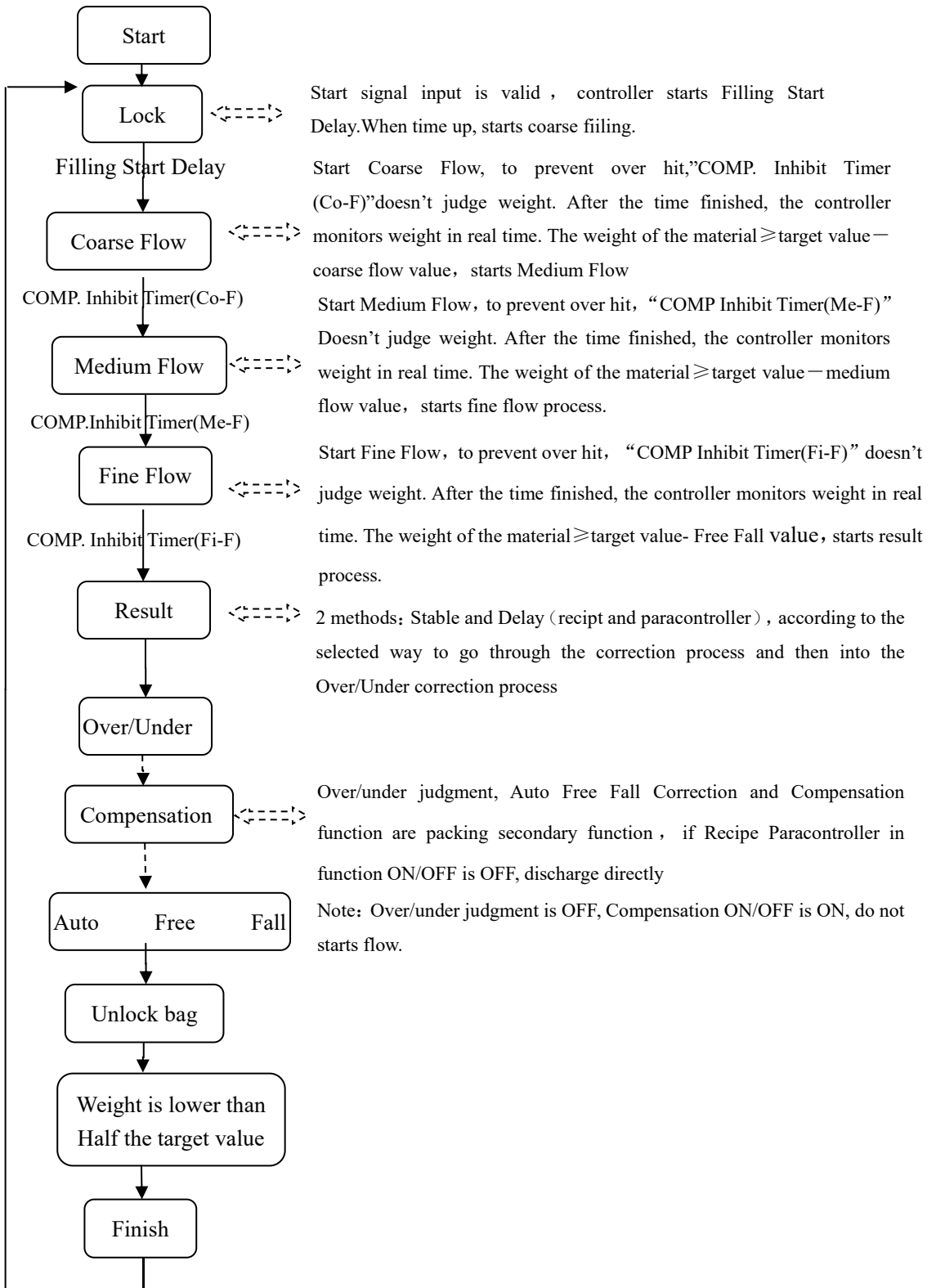

7.3 Tons of package scale

Process description:

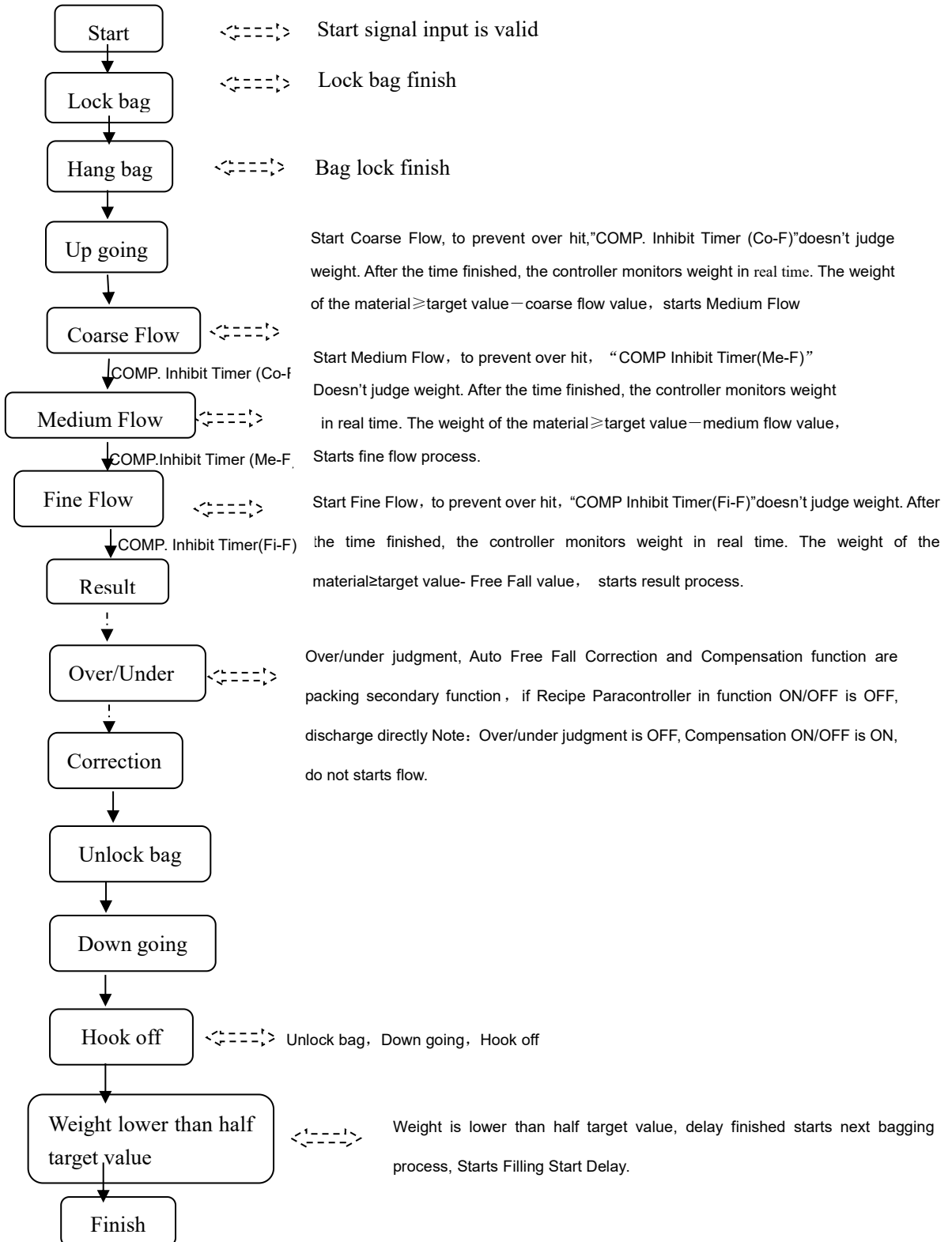

7.4 Valve port scale

Process description:

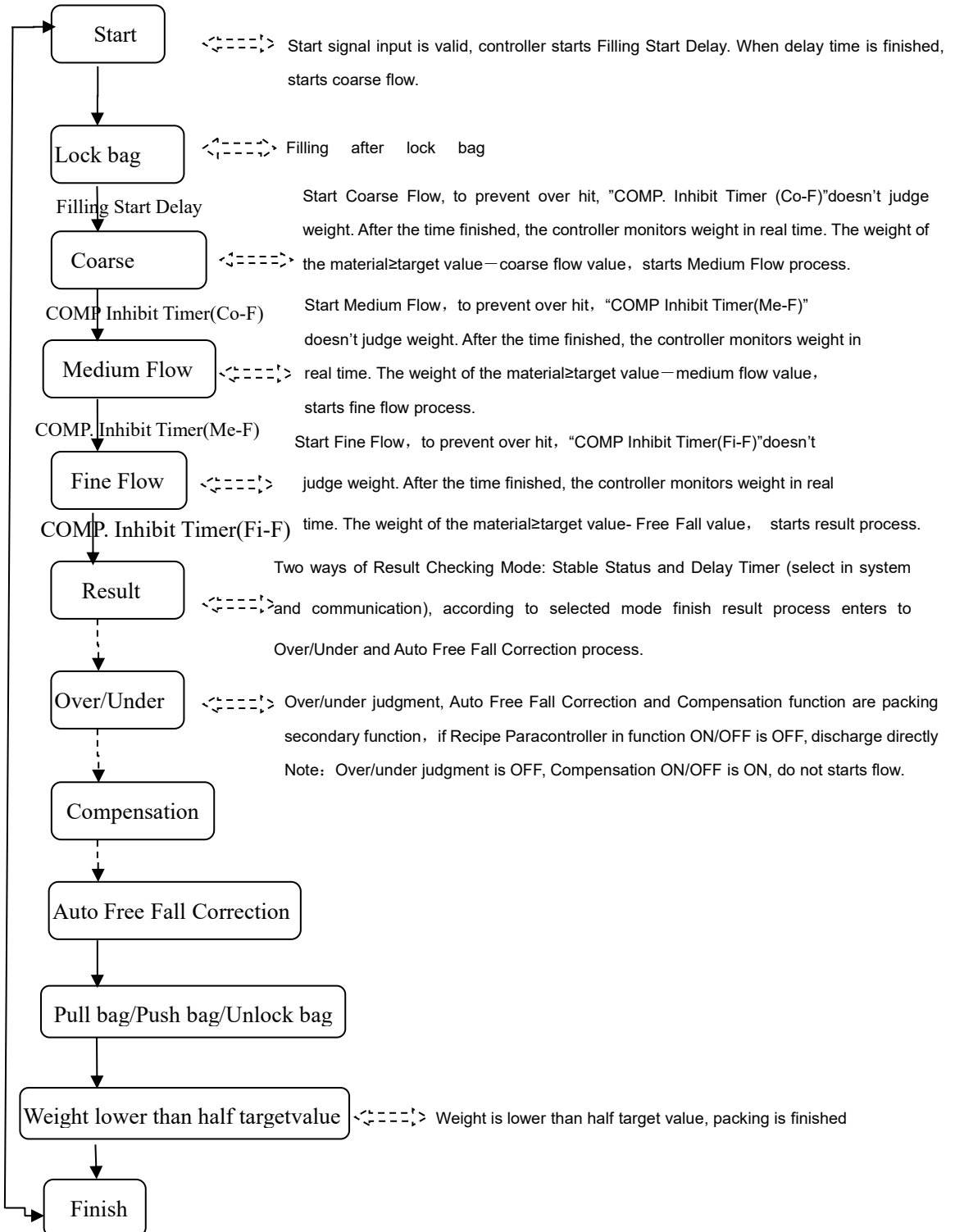

7.5 PLC mode

In the PLC mode, the status displayed on the main page of the controller is changed to: coarse add, medium add, fine add, over tolerance, undershoot, upper limit, lower limit, zero zone.

When the weighing process starts, the quick addition, medium addition, and fine addition output are effective, and the main interface displays the coarse addition, medium addition, and fine addition in sequence.

When the weighing value > target value + excess value, the out-of-tolerance output is valid.

The under output is valid when the weighing value < target value - underbalance value.

When the weighing value > upper limit value, the upper limit output is valid.

When the weighing value < lower limit, the lower limit output is valid.

When the weighing value < zero zone value, the zero zone output is valid.

7.6 Double scale interlocking bagging mode

The two controllers can be combined into two pairs of Net Weigher and double Gross Weigher scales by setting and wiring. The two measuring buckets can be weighed at the same time and connected to the same pocket mechanism. The two scales can be fed at the same time to improve the bagging speed. Setting 2 aspects, the working mode of the controller system and the communication paracontroller scale body structure are two controllers: interlocking **A** scale and interlocking **B** scale. **Note: The pockets are delayed by two controllers to be set the same.** Its structure is shown in the following figure: Refer to the following figure for ON/OFFing wiring:

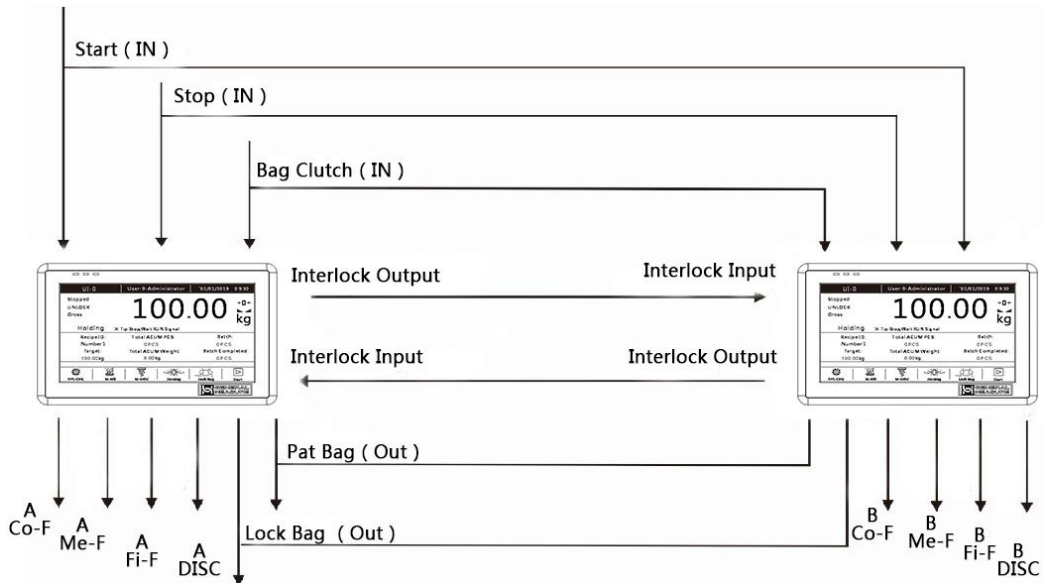

If the scale body mode selects the double Net Weigher interlock mode, the target values of the **A** scale and the **B** scale should be set separately, the quick addition, the

medium addition value, and the drop value, and the materials are separately measured from the storage hopper through the two filling mechanisms. Filling in the bucket (coarse, medium and fine filling), under the operating state, it can independently control the filling speed of **A** scale and **B** scale, the whole bagging process of unloading and automatic unlock bag. **The A and B scales** are first quantitatively completed before the unloading process.

- Lock bag

Net Weigher: **A** scale or **B** scale, first judge the pocket signal before unloading, start the pocket delay when the pocket signal is valid, the mechanism clamps the bag after the delay is over, and then starts the unloading action, who is **A** and **B** scale First, quantify who will discharge first. If one is discharging scale, the other scale even quantitatively complete, also need to wait for the next bag-scale signal is valid before unloading.

Gross Weigher: judge the pocket signal before filling. When the pocket signal is valid, both scales start the pocket delay. After the delay, the mechanism clamps the bag. After the bag is completed, the delay before filling is started to avoid leakage of materials. After the delay time of the bag is reached, the controller judges the stability, peels after stabilization, and the weight of the bag is used as the tare weight. Then the controller changes from the gross weight state to the net weight state and starts the filling process.

- Unlock bag

Net Weigher: the controller judges whether the material in the **A** scale or the **B** scale hopper is lower than the near zero value. If it is lower, the timer discharge delay is started. After the delay time is reached, the controller closes the unloading and starts the unlock bag delay. The unlock bag is automatically released after the delay of the unlock bag.

Gross Weigher: Start the unlock bag start delay after the setting, and automatically release the bag after the delay. (If there is a bag patting function, start the unlock bag start delay after the bag is finished). The controller controls the conveyor signal output and starts the conveyor.

8. Motor working process

8.1 Motor filling section

8.1.1 Stepper motor filling

Stepper motor mode control fill door ON/OFF: The ON/OFF quantity involved is: **(fill pulse output) / (fill direction signal), (fill gate closes in place), (signal in-position signal type determines)**.

Take the process of coarse filling and fine adding as an example:

- Coarse addition process: controller control **(motor rotation direction signal)** output, to ensure that the motor rotation direction is the door opening direction, then **(fill pulse output)** according to the set **filling motor frequency** to output pulses, control the filling stepper motor to turn in the door opening direction, **(When the number of filling pulse output reaches the set value, the output pulse signal is stopped, and the filling door stops rotating. At this time, it is in the coarse-adding state. Then the controller changes (motor rotation direction signal) output to the door closing direction.**
- In the process of adding: **(fill pulse output)** according to the set **filling motor frequency** to output pulses, control the filling stepper motor to turn in the closing direction, **(the filling pulse output)** reaches the set value and stops outputting the pulse signal, the filling gate Stop turning, this time is in the middle state.
- Fine addition process: **(fill pulse output)** according to the set **fill motor frequency** to output pulses, control filling stepper motor continues to turn in the closing direction, **(fill pulse output)** number reaches the set value and then stop output pulse signal, filling door stops rotating, in this case the fine fill state.
- Filling off: **(filling pulse output)** According to the set **filling motor frequency** , the pulse is output, and the filling stepping motor continues to rotate in the closing direction until the detection **(filling door closes in place)**. **The** input pulse is stopped after the input is valid, and the filling gate stops. Rotate, at this point the fill is completely closed.
- Note: If the closing process time exceeds the **filling door closing timeout time** set by the filling closing timeout time, the controller has not detected **(the filling door is closed in place)**, then the controller will stop **(fill pulse output)** , and the alarm **filling will close the timeout** .

8.1.2 Ordinary motor filling

Ordinary motor mode control fill door ON/OFF: The I/O Module involved is: **(adding material to open the door) / (adding material to close the door), (the filling door is closed in place)**.

Take the process of coarse filling and fine adding as an example:

Take the process of coarse filling and fine adding as an example:

Coarse filling process: The filling process starts after the delay time. The controller first makes the (filling and opening) signal output valid, the effective time is the coarse opening time, and the coarse filling process begins.

- In the process of medium filling: When the weight of the material in the hopper \geq the single scale target value - coarse increase the advance amount, the signal output (filling closes) is valid, and the effective time is "coarse opening time - medium opening time".
- Fine filling process: When the material weight in the hopper \geq single scale target value - medium advance amount, the (filling closes) signal output is valid, the effective time is "medium plus door opening time - fine plus door opening time"
- Filling off: When the material weight in the hopper \geq single scale target value - fine plus advance, the **(fill closing)** signal output is valid until the **fill door in-position signal is detected (the fill door is closed)**.

8.2 Motor lock bag part

8.2.1 Step motor lock unlock bag

Stepper motor mode control lock unlock bag: The ON/OFF quantity involved is: **(lock bag pulse output) / (lock bag direction signal) / (unlock bag in place)**, (signal is determined by the type of in-position signal).

Take the process of clamping the unlock bag in the measuring bucket mode as an example:

- Lock bag process: the controller control **(lock bag direction signal)** output, to ensure that the motor rotation direction is the bag direction, and then **(lock bag pulse output)** according to the set **bag motor frequency** to output pulses, control lock unlock bag stepping. The motor rotates in the direction of the **pocket, and the number of pulses required** to set the **pocket is stopped** after the **number of pulses required** to set the **pocket is stopped**. At this time, the pocket mechanism is in the pocket state. Then the controller changes **(the signal of the pinch pocket direction)** and the output is in the direction of the unlock bag.
- Unlock bag process: **(pinch bag pulse output)** according to the set **unlock bag motor frequency** to output pulses, control the unlock bag stepper motor to the direction of the unlock bag, until the detection **(unlock bag in place)** input is valid, stop output pulse signal. In this case the bag is unlock state. Note: If the unlock bag process time exceeds the set **unlock bag process timeout period**, the controller has not detected **(the unlock bag is in place)**, then the controller will stop output **(lock bag pulse output)**, and the alarm will call **the unlock bag timeout**.

8.2.2 Motor double limit lock unlock bag

Ordinary motor double limit control lock unlock bag: The ON/OFF quantity involved is: **(lock bag) / (unlock bag), (lock bag in place) / (unlock bag in place). (The signal is determined by the type of signal in place).**

Take the process of adding a unlock bag in the measuring bucket mode as an example:

- Process lock bags: a signal controller output control lock folder bag to bag-bulk bags motor rotational direction, until a bag-detected signal and outputs the stop bit input signal is active folder bag, the bag clamp mechanism is in this case the bag sandwiched state. Note: If the bagging process time exceeds the set **bagging process timeout period**, the controller has not detected the bag in place signal, then the controller will stop outputting the bagging signal and the alarm **bagging process will time out**.
- Process unlock bags: unlock bags signal controller output control lock unlock bulk bags of rotation of the motor direction of the bag, the bag in place until detecting unlock bulk bags stops outputting the signal after the input signal is active, whereupon the bag-state mechanism is unlock bags. Note: If the unlock bag process time exceeds the set **unlock bag process timeout period** and the controller hasnot detected the unlock bag in-position signal, the controller will stop outputting the unlock bag signaland the alarm **unlock bag process will time out**.

8.2.3 Motor single limit lock unlock bag

Ordinary motor dual output control control lock unlock bag: the amount of ON/OFF involved is: **(lock bag) / (unlock bag), (lock bag in place).**

Take the process of adding a unlock bag in the measuring bucket mode as an example:

- The bagging process: the controller controls the ON/OFF output signal, and the output signal until the detection of the pocket in-position signal input is valid, the output signal output is invalid, and the device pocket is realized.
- The unlock bag process: the controller controls the ON/OFF output signal to realize the unlock bag of the device, and the output signal duration is the unlock bag output, and the output signal output is invalid.

8.3 Motor discharge part

8.3.1 Stepper motor discharge

Stepper motor control discharge: The ON/OFF quantity involved is: **(discharge pulse output), (discharge direction signal), (discharge opening door is in place).**

Take the unloading as an example:

Discharge opening process: controller control **(discharge direction signal)** output, to ensure that the motor rotation direction is the door opening direction, and then **(discharge pulse output)**according to the set **discharge door motor frequency** to output pulses, control the discharge stepper motor to the direction of rotation of the discharge door, stops

outputting a pulse signal(**output pulse discharge**) the value of the number reaches **the number of pulses required to set the discharge**, the discharge mechanism is in the open state at this time

- Discharge closing process: After the discharge door is opened, if the weight of the controllerdetection hopper is lower than the **near zero value**, the **discharge delay time** will be started. After the discharge delay time is over, the controller change (**discharge direction signal**) output is closed. Direction, (**discharge pulse output**) according to the set **discharge motor frequency** to output the pulse, control the discharge stepper motor to rotate in the closing direction, until the detection (**discharge door open in place**) input is valid, stop output pulse signal, this The time is closed. Note: If the door closing process time exceeds the set **discharge closing timeout time** , thecontroller has not detected the door closing in-position signal (**the discharge door is in place**) , then the controller will stop output (**discharge pulse output**) , and the alarm **unloading closes the door timeout** .

8.3.2 Motor single limit discharge

Ordinary motor forward and reverse single limit mode to control unloading: the ON/OFF quantity involved is: (**unloading to open the door**), (**unloading to close the door in place**).

Take the unloading process as an example:

- Discharge opening process: At the beginning of the unloading process, the controller output discharge signal controls the unloading motor to rotate in the direction of the discharge opening, and continuously **discharges the door opening output effective time** set discharge motor door opening signal output time, and then closes the unloading signal Output.

- Closing the discharge process: After the discharge door is opened, the controlleration near the hopper weight is less than zero, then the discharge start delay time, delay time after the discharge, the discharge door closing output signal, to control the discharge motor closing the discharge direction of rotation until the sensed discharge doors close off the discharge stops outputting the input signal is position signal active, whereupon the discharge door in a closed state. **Note**: If the discharge door closing process time exceeds the set **discharge closing timeout time**, the controller has not detected the discharge door closing in-position signal, then the controller will stop output and the alarm **discharge closes the timeout** .

8.3.3 Motor double limit discharge

Ordinary motor forward and reverse double limit mode control discharge: the ON/OFF quantity involved is: (**unloading**) (**unloading closes the door**), (**unloading closes the door**) / (**unloading opens the door in place**).

Take the unloading process as an example:

- Discharge opening process: At the beginning of the unloading process, the controller output discharge signal controls the unloading motor to rotate in the direction of the unloading door opening, until the discharge door in-position signal input is detected to stop outputting the discharge signal, and the discharge door is discharged. Is open. Note: If the discharge door opening process time exceeds the set **discharge opening timeout time**, the controller has not detected the discharge door open door in-position signal, then the controller will stop output, and the alarm **unloading will open the door timeout**.

- Discharge closing process: After the discharge door is opened, The controller near the hopper weight is less than zero, then the discharge start delay time, delay time after the discharge, the discharge output closing signals to control the discharge motor is rotated in the closing direction of the discharge until the sensed discharge Close door input valid signal in place to close the discharge stop signal is output, when the discharge doors in a closed state. Note: If the discharge door closing process time exceeds the set **discharge closing timeout time**, the controller has not detected the discharge door closing in-position signal, then the controller will stop output and the alarm **discharge closes the timeout**.

8.3.4 Motor one-way rotary discharge

Ordinary motor one-way rotation one-week single limit mode control discharge: the ON/OFF quantity involved is: **(unloading), (unloading closes the door in place)**.

Take the unloading process as an example:

- Discharge opening process: At the beginning of the unloading process, the controller output discharge signal controls the unloading motor to rotate in the direction of the discharge opening, and continuously sets the **discharge motor to open the door signal output time**, and then closes the discharge signal output.

- Discharging and closing process: After the unloading door is opened, if the controller detects that the weight in the hopper is lower than the near zero value, the discharge delay time is started. After the discharge delay time is over, the discharge signal is output, and the unloading motor continues to be controlled. closing the discharge direction of rotation until the sensed discharge doors closing the discharge stops outputting the input signal is position signal active, whereupon the discharge door in a closed state.

- **Note:** If the discharge door closing process time exceeds the **discharge closing timeout time**, the controller has not detected the discharge door closing in-position signal, then the controller will stop output and the alarm **discharge closes the timeout**.

8.3.5 Motor debug function

- Motor debug function is for the convenience of users quickly determine the door size of coarse, medium, fine flow. Take door size of debug fine flow for example as below.

Steps as below:

- 1: The left side of the interface is the current coarse, medium, fine pulse count. You can modify the data in fine flow pulse input box.
- 2: Click“Open fine flow”button, then controller ouput fine flow signal. User can determine whether the current pulse is appropriate by checking the opening size of the charging door. (Note: click "close fine flow" again to close fine flow.Controller can only be in a state, can not be in the state of coarse flow or medium flow at the same time),
- 3: If the pulse number has been modified, press the "save" button to save the modified pulse number, If do not want to save the modified pulse number, exit the motor debugging interface to restore the previous coarse ,medium , fine pulse number.

9. Peripheral workflow

9.1 Pat bag

The amount of ON/OFF involved in the bag making function is: "patting bag".

The bag-making function consists of three optional processes: "Bag in the filling", "Bag after setting", "and extra bag".

(Note: The extra bag function is not available in PLC mode).

If you want to use the bag making function, first set the bag shooting function in the bag paracontrollers under the peripheral paracontrollers. Different scale body structures are different depending on the optional bag mode.

In the filling bag:

During the filling process, if the bag in the filling is set, when the current weight is greater than the starting weight of the bag, the bag in the filling starts, and the output of the bag effective time and the bag invalid time are regarded as one bag at a time. After the "number of shots in the filling" is reached, the output of the shot bag in the filling is stopped.

After the value is taken, the bag is:

After the fixed value is over, if the set value is set and the bag is taken, the bag will be taken directly after the fixed value is set, and the output of the "bag valid time" and the "bag invalid time" will be regarded as one shot at a time, after reaching the "set value". After the number of times the bag is taken, the bag output is stopped after the fixed value is stopped.

Extra patting bag:

After all the bags are output, an additional bag output is performed. The effective time is the effective time of the extra bag output, and the invalid time is the bag invalid time. End the extra shot output after the bag is taken once.

9.2 Coding

The amount of ON/OFFing involved in the coding function is: "code".

After the pocket is completed, if the code ON/OFF is turned on and the "code valid time" is not 0, the "code start delay" will be started. After the delay is over, the code delay will be started. The time is "coded effectively". Time", after the time is up, the coding process ends.

(Note: If "Do not allow unloading ON/OFF when coding" is turned on, the loading and unloading function is prohibited during the code process)

9.3 Conveyor

The amount of ON/OFF involved in the conveyor function is: "conveyor output". After the fixed value is over, check whether the "conveyor ON/OFF" is turned on. When it is turned on, run the "conveyor start delay time". After the delay time, the conveyor starts to run, and the "conveyor running time" is counted. Stop running. Under the bucket scale structure, if the previous scale conveyor is still running, stop the conveyor before unloading. Under the structure without bucket scale, if the conveyor of the previous scale is still running, stop the conveyor before the unlock bag.

9.4 Printing

After connecting the printer, you need to set the communication paracontrollers of the controller and select the communication method as the printing method. The print format is available in 24 columns and 32 columns. The language is available in both English and Chinese, and the number of lines to be printed can be set.

9.5 Sewing machine

The number of ON/OFFes involved in the sewing machine function is: "sewing machine output", "cutting machine output", "sewing machine start", "sewing machine emergency stop".

When the sewing machine ON/OFF is effective, the sewing machine starts to delay. When the delay time reaches, the sewing machine starts to work. The continuous output time is the output time of the sewing machine. After the output time of the sewing machine arrives, the delay time before the sewing machine is started and the delay time of the cutting machine is started. Sewing machine continues to work output, the duration of the sewing machine shutdown delay time. Tangent machine start delay time, when the tangent machine start delay time arrives, the tangent machine begins to work, the working time is the output time of the tangent machine, the tangent machine stops working after the output time arrives.

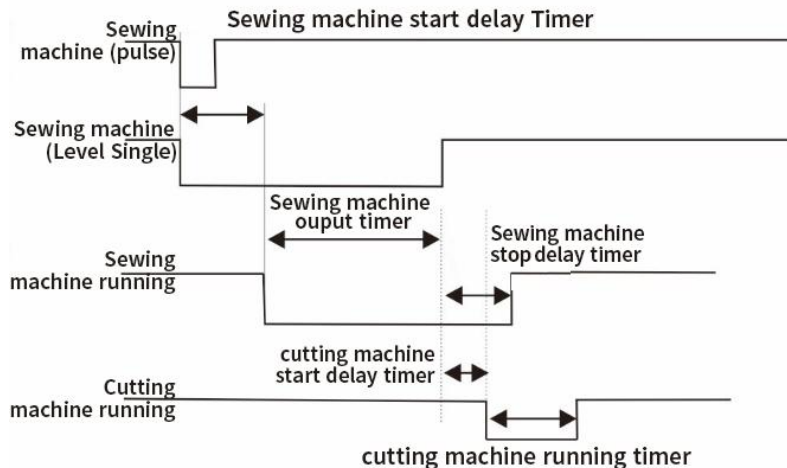

9.6 Discharge Patting

Discharge Patting function involved I/O modules are: Output I/O module- “Discharge Patting” .

When discharging mode to open the closed after opening, if the current discharging time is longer than the set of discharge time effectively, began to discharge shaking output, according to an effective time and discharging shaking a discharge shaking invalid combination for a discharge time shaking, when discharging vibrating frequency reaches the set of discharge after the vibrating frequency, discharge end of the vibrating process and output alarm stop

9.7 Filling/Discharge Overtime Paracontroller

If “Filling/Discharge Overtime Paracontroller” turns on, in running state, in the process of coarse, medium and fine adding and discharging, if the current process delay is longer than the set timeout time of coarse, medium and fine adding and discharging, the output timeout alarm and stop.

9.8 Auxiliary Pulse

Auxiliary Pulse function involved I/O module are: “Auxiliary Pulse input 1~4”、“Auxiliary Pulse output 1~4” .

Take Auxiliary Pulse 1 for example:

Auxiliary mode:

In controller stopped or running state, when the I/O Module input "auxiliary pulse input 1" effectively, the switch output auxiliary pulse output "1" to start the output, continuous output Settings "auxiliary pulse duration 1", after time to stop output, waiting for the set of "auxiliary pulse 1 no time" to the later, once again began to output. Stop output until the "total execution time of auxiliary pulse 1" reaches, and turn off the auxiliary pulse switch.

If the "total execution time of auxiliary pulse 1" is set to 0, the output process will continue in a loop.

During the execution of the auxiliary pulse, if the switch input auxiliary pulse input 1 is valid, the output of the auxiliary pulse 1 will stop.

Level mode:

1. Set paracontrollers and I/O Module: Click the paracontroller of "auxiliary pulse mode" in "peripheral paracontrollers" - "auxiliary pulse", select the type of "level mode" for the corresponding pulse, set the "effective time of auxiliary pulse" of the corresponding pulse as 2 seconds, and set the "invalid time of auxiliary pulse" of the corresponding pulse as 2 seconds. Select the input port and output port of the auxiliary pulse in the "IO function definition" paracontroller.

2. Perform operation: select [Level Mode], continue to give high level at the input end set, and start the effective time of auxiliary pulse at the same time, and continue to be

effective until the effective time of auxiliary pulse ends at 2s. At this point, the output of the trigger signal becomes invalid until the invalid time of the auxiliary pulse ends at 2s. When the invalid time of auxiliary pulse ends, the output end becomes effective again, and the effective time of auxiliary pulse is restarted, so as to cycle. Until the input terminal no longer input high level, the output signal port no longer output high and low level.

10. Dimension (mm)

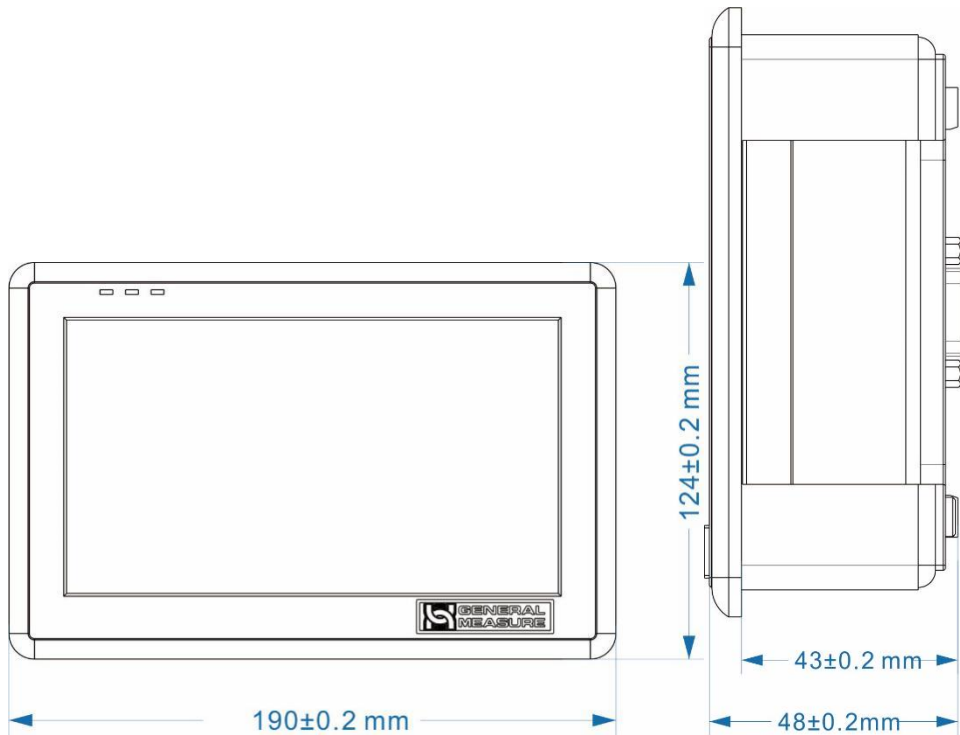

Mounting hole size

